

Operation Manual

PCX 5200 Post-column Derivatization Instrument



www.md-scientific.dk
Denmark

**PICKERING
LABORATORIES**

Pickering Laboratories, Inc.
1280 Space Park Way
Mountain View, CA 94043

(800) 654-3330
International: (650) 694-6700
Fax: (650) 968-0749

Website: <http://www.pickeringlabs.com>
E-mail: support@pickeringlabs.com

Cat. No. 0101-0001

Version 6, January 2002

© Pickering Laboratories, Inc.

Contents

Please Read	BYS-1
Symbols	BYS-1
Chapter 1 • Introduction	
Why Post-column Derivatization?	1-1
How Does It Work?	1-1
What Are the Requirements?	1-1
Pickering PCX5200	1-2
Reagent Delivery	1-2
Column Protection	1-2
Supplement—The Elements of an HPLC with Post-column System	1-4
Design of an HPLC	1-4
A Simpler View of an HPLC	1-5
Designing a Post-column System	1-5
Chapter 2 • PCX5200 System Components	
PCX5200 Post-column Instrument	2-1
Getting to Know Your PCX5200	2-1
Front Panels	2-1
Internal	2-3
Rear Panel	2-4
Column Oven	2-6
Reagent Reservoirs	2-8
External Reagent Pressurization System	2-9
Keypad and Liquid Crystal Display User Interface	2-10
Keypad Examples	2-13
Loading a Preset	2-13
Saving a Preset	2-15
Flow Diagrams	2-18
PRESET Key	2-18
PROG Key	2-18
Specifications	2-20
Wetted Materials, PCX5200	2-20
PCX5200 PEEK	2-20
Ratings	2-20
RS232 Serial Port	2-21
Downloading firmware	2-21
Radio frequency	2-21

Chapter 3 • Installation

Unpacking.....	3-1
Site Requirements	3-1
HPLC System Requirements	3-1
Space Requirements	3-2
Electrical Requirement	3-2
Inert Gas	3-2
Miscellaneous Supplies.....	3-2
Installation of the PCX5200	3-2
Layout of the HPLC and PCX5200	3-2
Note About Fittings	3-3
Inert Gas	3-3
Reagent Reservoir Connections	3-3
Pressure-interlock Connections	3-4
Injector Connections	3-6
Detector Connections	3-6
Guard & Analytical Column Installation	3-7
Reagent Pump	3-8
Piston-wash System	3-8
Priming the Reagent Pump	3-9
System Testing & Verification	3-9
Shutdown	3-10
Short-term	3-10
Medium-term	3-11
Long-term	3-12

Chapter 4 • Routine Maintenance & Troubleshooting

Initial System Testing	4-1
Test Chromatogram	4-1
Paramater Log	4-1
Precautions & Problem Prevention	4-2
Mobile Phase	4-2
Back-flow Prevention	4-2
Reactor Precautions	4-2
Electrical Precaution	4-2
Routine Maintenance	4-3
Reagent Pump	4-3
Pump Seal Replacement	4-3
Check-valves	4-6
Cleaning Check-valves	4-6
Removing Check-valves	4-7
Installing New Check-valves	4-7
Rebuilding Check-valves	4-8
Pre-column Filter	4-9
Reagent Filter	4-10
Ambient Reactor (not applicable to single reagent PCX5200)	4-11

Heated Reactor	4-11
Fuse	4-12
Troubleshooting Guide	4-12
Advice	4-12
When Priming the Reagent Pump is Difficult	4-13
Interpretation of Pressures	4-14
Two-reagent PCX5200	4-14
One-reagent PCX5200	4-14
Cleaning the Post-column System	4-15
Fittings	4-15
External	4-15
Internal	4-15
Internal Spill	4-15
Appendix A	
PCX5200 Parameter Log	A-1
Analytical Conditions	A-2
Post-column Band-spreading Test	A-3
Appendix B	
Spare Parts	B-1
References	
Limited Warranty	
Index	

Before You Start Please Read

- Please Read**
- Page 2-8 for the safety requirement of *coated-bottles*; they must not be substituted!
 - Page 3-1 for the HPLC System Requirements, especially for *glyphosate or amino acid analysis!* For most ion-exchange applications, the HPLC components must be compatible with *high pH regenerant*.
 - Pages 2-3 and 3-8 about the *piston-wash system* of the post-column pump

Symbols



A **note** supplies supplementary information which may be helpful or necessary for better understanding of the material.



The **caution** calls attention to an operating procedure, practice, or the like, which if not correctly done or adhered to, could result in loss of information, or damage to, or destruction of part or all of the equipment. Do not proceed beyond a caution sign until the indicated conditions are fully understood and met.

The following symbols appear on the PCX5200 or its accessories.



This warning sign denotes a hazard. It calls attention to a procedure, practice, or the like, which if not correctly done or adhered to, could result in injury or loss of life. Do not proceed beyond a warning sign until the indicated conditions are fully understood and met.

Ce symbole est un signal de danger. Il indique qu'une manipulation, si elle n'est pas respectée ou effectuée correctement, risque d'entraîner des blessures, voir la mort.

Dieses Warnsymbol kennzeichnet eine Gefahr. Es macht aufmerksam auf einen Vorgang, eine Handhabung oder ein Vorhaben, die bei unkorrektem Befolgen der Vorschriften zu einer Verletzung oder einer lebensgefährlichen Situation führen können.

El signo de atención indica un riesgo. Requiere atención sobre un procedimiento, práctica, o similar, que, si no se ejecuta correctamente o se sigue minuciosamente, podría producir heridas o muerte. No continúe a partir de un signo de atención hasta que no se hayan entendido y alcanzado completamente las condiciones indicadas.

Questo avvertimento informa del pericolo. Molto attenzione riguardante il moto di usare questa macchina é molto importante altrimenti risulterà danni e anche morte. Non continuare di piu affinché le condizioni e istruzioni sono completamente chiare.



This warning sign denotes a hot surface, a high temperature hazard. It calls attention to a column heating block hotter than 70°C. For your safety, wear insulating gloves when the column oven is warm.

Ce symbole indique une surface brûlante. Il signifie que la résistance chauffante de la colonne a atteint une température supérieure à 70°C. Pour votre sécurité, prière de porter des gants isolants.

Dieses Warnsymbol kennzeichnet eine heiße Oberfläche oder eine Gefahr durch hohe Temperaturen. Es macht aufmerksam auf den Heizblock des Säulenofens, der heißer als 70°C sein kann. Zu Ihrer Sicherheit sollten Sie isolierende Handschuhe tragen, wenn der Säulenofen warm ist.

Este signo de atención indica una superficie caliente, un riesgo de alta temperatura. Pide atención sobre un bloque calefactor de columnas por encima de 70°C. Para su seguridad use guantes aislantes cuando el horno de columnas esté caliente.

Questo avvertimento informa della temperatura molto alta che possibilmente potrebbe bruciare. Molto attenzione é necessaria specialmente al blocco caldo della colonna che é superiore ai 70°C. Per essere protetti é necessario usare guanti insulanti per questa applicazione.



Power On

En marche

An

Escendido

Acceso



Power Off

Éteint

Aus

Apagado

Spento



Fuse Specification

Spécification du fusible

Spezifikation der Sicherung

Fusible

Valvole Specificazioni



Protective Ground

Prise de terre

Erdung

Masa de protección

Protezioni a terra

Why Post-column Derivatization? Post-column derivatization, also known as post-column reaction, renders visible certain compounds that are normally invisible. This trick is accomplished after the separation by performing a chemical reaction on the substances that gives them an easily detectable physical property. Typically you use a reaction that produces a strong color or makes a fluorescent product. You can increase the sensitivity of detection by several orders of magnitude in favorable cases. Most reagents are selective for a particular class of substances, so analytes of that class are more easily seen against a complex background. So, post-column derivatization is used to increase sensitivity and selectivity in HPLC analysis.

How Does It Work? The post-column reaction system mixes the stream of effluent flowing from the HPLC column with a stream of reagent solution. The mixture usually flows through a reactor to allow enough time for the chemical reactions to complete. If the reaction is slow, the reactor may be heated to speed things up. Some reactions need two or more reagents added in sequence. Finally, the mixed streams pass into the detector, typically UV/VIS absorbance or fluorescence. Of course, a practical system requires metering pumps, pulse damper, thermostats, and safety systems to give reliable results.

What Are the Requirements?

- **Stability of Reagent.** The minimum reagent stability sufficient for routine work is one day. This means that the yield and signal-to-noise ratio for a given sample must remain constant for at least 8 hours.
- **Speed of Reaction.** The analytical separation is complete when the reagent is mixed with the column effluent. Therefore, in order to minimize band spreading, it is important to keep the time (therefore volume) small between the mixing tee and the detector. If the reaction is slow (in excess of one minute), an elevated temperature can be used to decrease the reaction time.
- **Reproducibility.** Because the reaction is occurring “on the fly,” as the combined column and reagent stream flows toward the detector, the reproducibility is linked to the flowrate precision of the pumps and to the temperature. Accordingly, even an incomplete reaction will be as repeatable as the retention time for any given species. The completeness of the reaction, then, is not strictly necessary for reproducibility, but it is important for maximum sensitivity.
- **Minimal Detector Response of Reagents.** The color or background fluorescence of the reagent (or its by-products) represents a continuous noise source. Because the reagent is present in excess relative to the analyte, the analyte’s signal could be obliterated by the reagent’s strong background signal. The baseline noise is proportional to the background signal.

- Solubility. All species must remain in solution, including the combined components of the eluants and the reagent(s), as well as the newly formed derivative(s). Precipitates can block capillary tubes, burst reactors, and foul detector flowcells.
- Uniformity of flow. The baseline noise is a function of the flow-noise in the eluant and reagent pumps. Non-uniform flow causes non-uniform mixing leading to modulation of the background signal which appears as noise. Refractive index noise can be even more objectionable than absorbance noise.

Pickering The PCX5200 does three main things (Figure 1-1):

- PCX5200**
1. Thermostats the analytical column
 2. Delivers the reagent
 3. Heats the reaction.

It also has various features to make the analysis more convenient or reliable, and features to protect the instrument itself from accidental damage.

Reagent The pressurized reservoir serves two purposes:

- Delivery**
1. It protects air-sensitive reagents from oxidation.
 2. It helps the metering pump fill consistently by preventing cavitation.

The pump is a constant speed, variable-stroke piston pump. The cam cycle is two seconds, which makes for easy pulse damping.

The reagent pressure gauge does two things:

1. It shows the pump pressure for diagnostic purposes.
2. It absorbs pulses by the spring action of the Bourdon tube. There is a packed-bed restrictor just downstream to provide a load for the pressure gauge so that it will effectively absorb pulsations.

Referring to Fig. 1-1, the anti-siphon valve prevents the gas pressure in the reservoir from forcing liquid through the system with the power off. The post-column pressure gauge is primarily there to monitor the condition of the reactor. There is a 500 psi relief valve in case there is a blockage in the reactor or detector. The standard reactor is a PTFE capillary tube 0.011" I.D. wrapped on a heated mandrel. The narrow diameter reduces band-spreading, and the PTFE is corrosion resistant. There is a 100 psi (5 bar) back-pressure regulator on the exit line from the detector; it suppresses boiling inside the hot reactor and prevents bubbles from forming in the detector flowcell.

Column Usually, the post-column reagent will immediately damage the analytical column. To
Protection prevent this, there is a pressure switch connected between the HPLC pump and the injector that must sense 500 psi (35 bar) before allowing the reagent pump and reactor to receive power. If at any time pressure is lost because of fault or programmed shutdown, the PCX5200 will gracefully shut itself off until a human turns it back on.

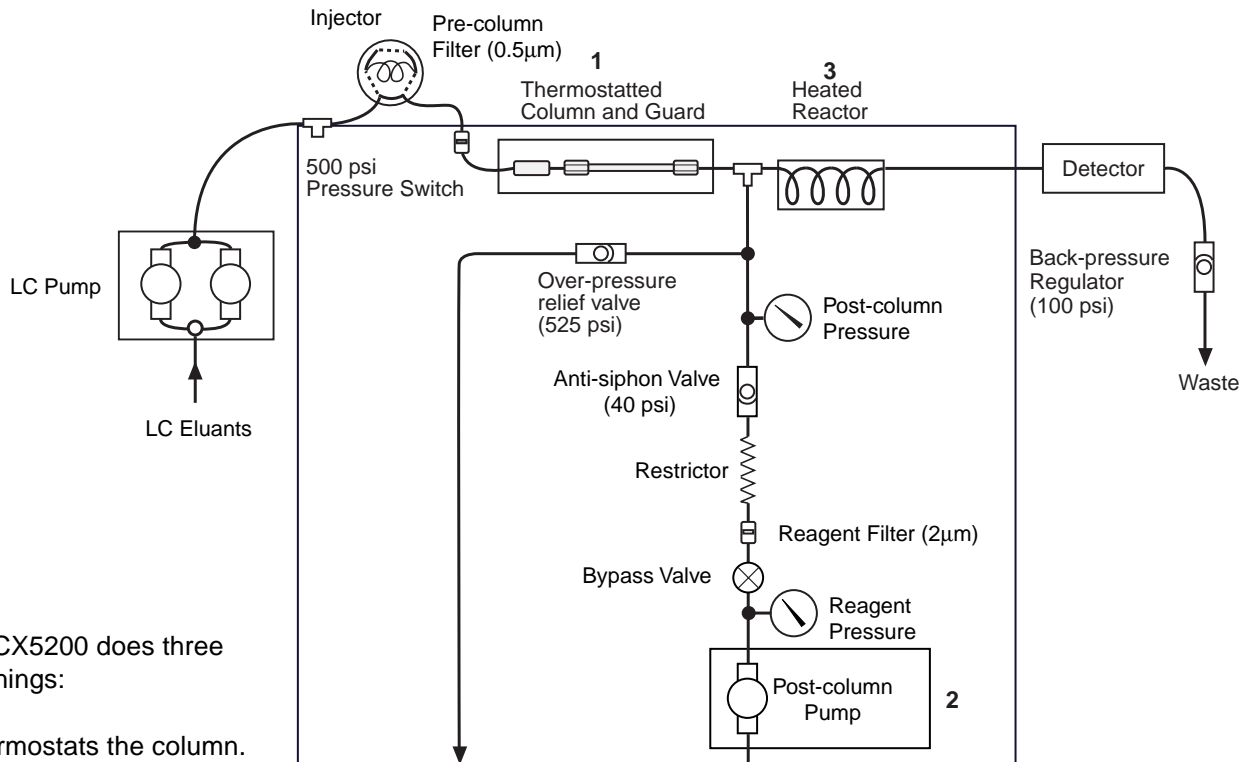

The PCX5200 does three main things:

1. Thermostats the column.
2. Delivers the reagent.
3. Heats the reaction.

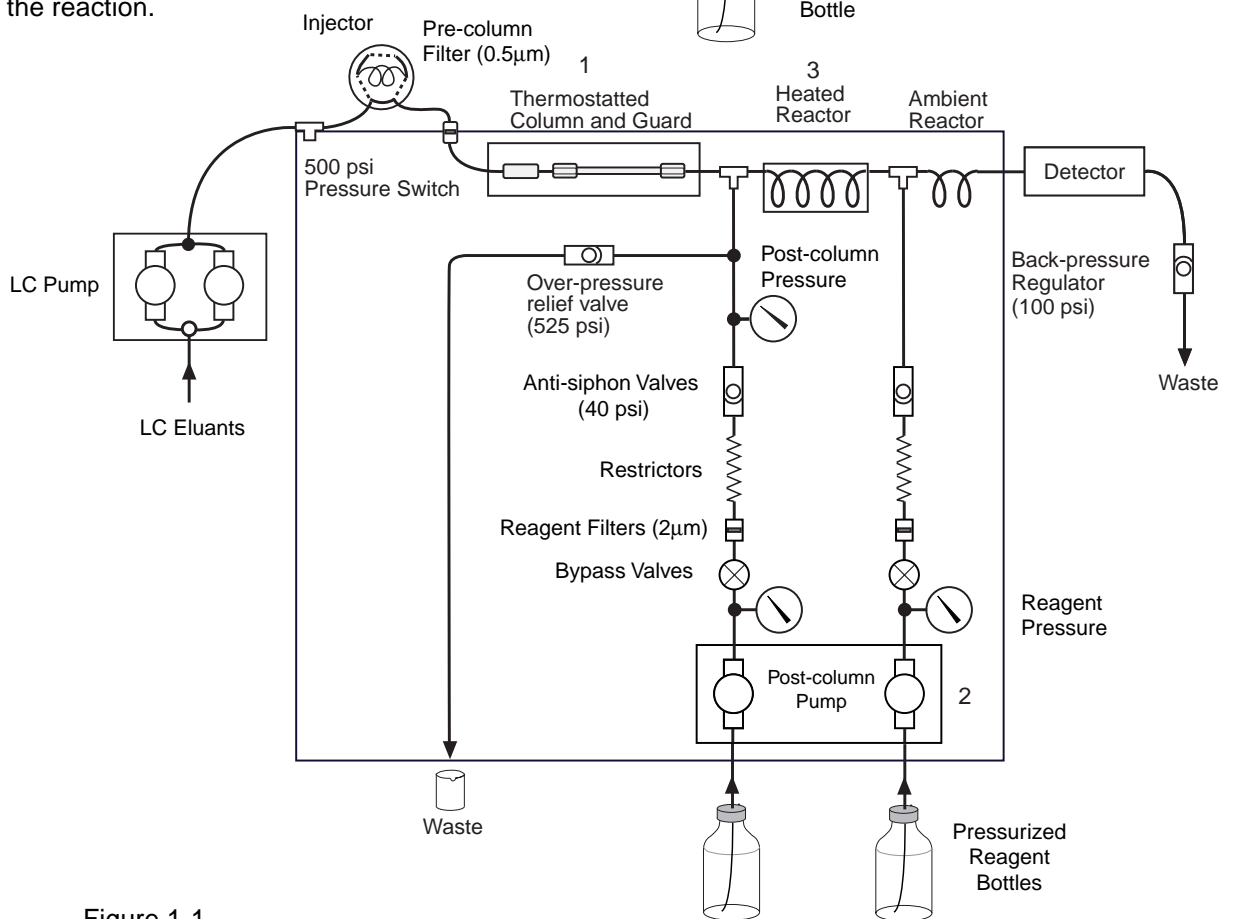
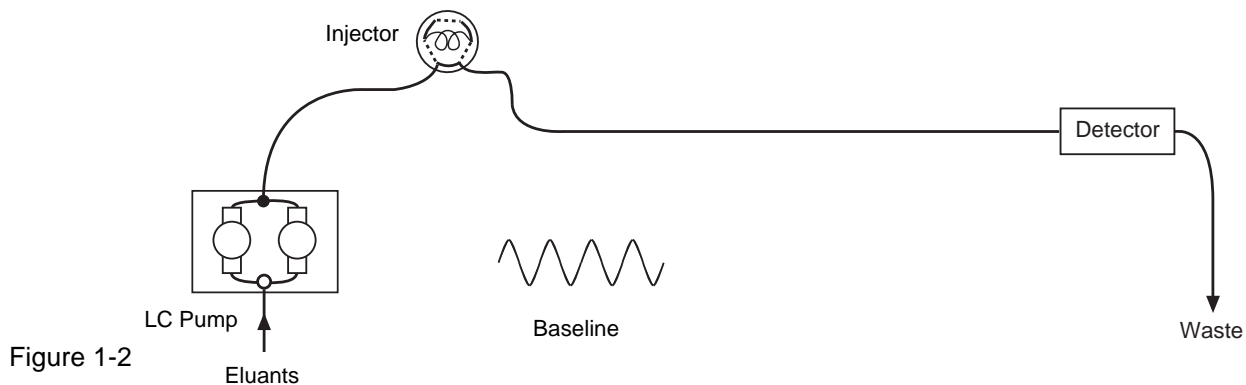

Figure 1-1
 Picking post-column systems: one- and two-reagent

The Elements of an HPLC with Post-column System This next section is a simplified view of a post-column system and it is intended to help novice HPLC operators.

Design of an HPLC In order to understand post-column HPLC, we need to understand the design of an HPLC. If we connect an HPLC pump directly to a detector (with nothing in between), the baseline from the detector shows a periodic noise (Figure 1-2); the time period is equivalent to the pump stroke.



Now add a commercial "pulse damper." The baseline is still not smooth; the periodic noise is still there although less pronounced (Figure 1-3).

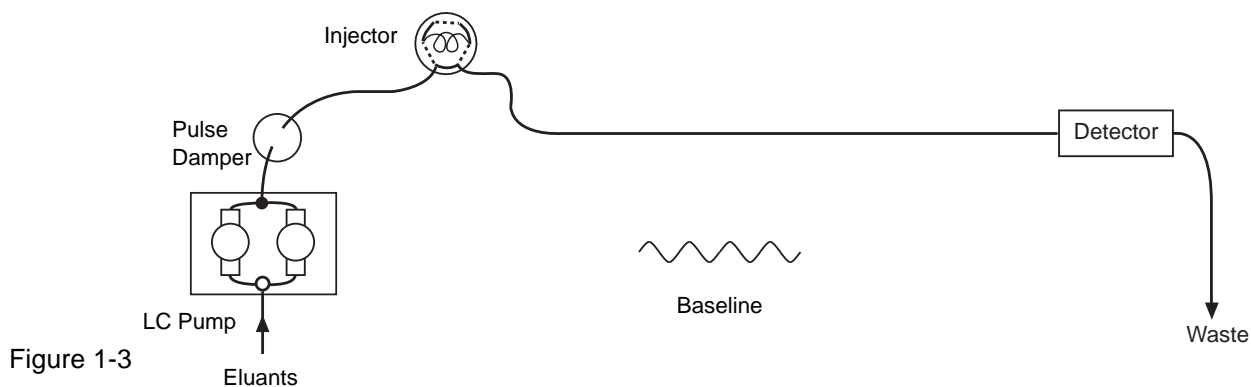

What we need is a column. The column does more than separation. It creates a back-pressure. It is the combination of the “pulse damper” and the column that creates a smooth baseline. (Figure 1-4)

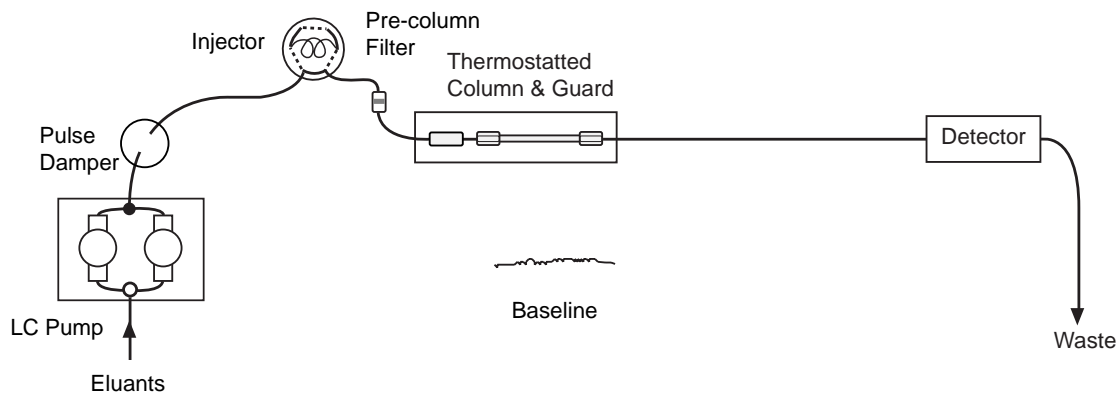

Figure 1-4

A Simpler View of an HPLC Let us use a river as an example. If it rains; the river swells. If it stops raining; the level goes down. As the level fluctuates, it is equivalent to a periodic noise. To obtain a constant flow, we need to add a reservoir (“pulse damper”) and a dam (column). The flow downstream from the dam is constant (smooth baseline).

Designing a Post-column System What happens if we simply add a post-column pump, a mixing tee, and a reactor? What happens to the baseline? The periodic noise returns (created by the post-column pump; Figure 1-5).

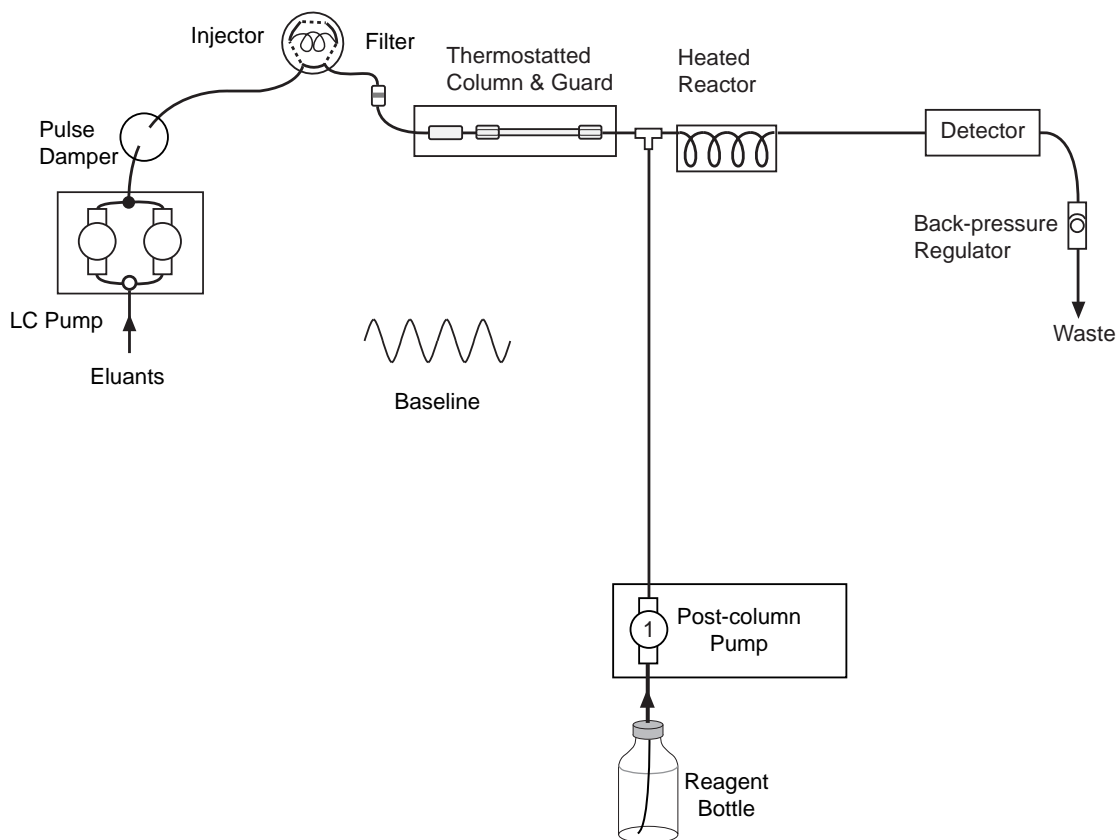

Figure 1-5

However we do not need to invent anything new; we just need a “pulse damper” and a column (at Pickering, we call it a restrictor; Figure 1-6).

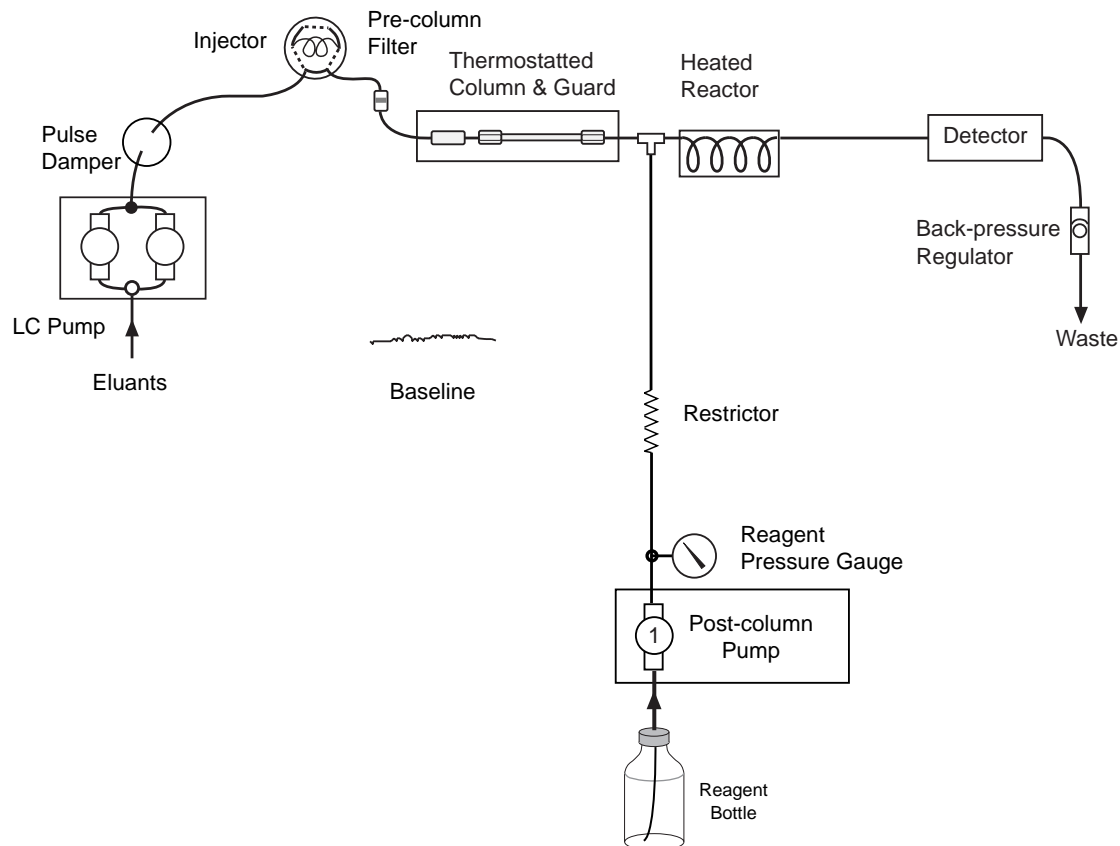

Figure 1-6

A Pickering flow-conditioner includes a pressure gauge and a restrictor. The Bourdon tube inside the pressure gauge is the “pulse damper” and the restrictor packed with very inert material is the column. With the flow conditioner in place, the baseline is now acceptable.

Add a second or third post-column reagent? Just follow the same procedure. Another post-column pump, pressure gauge, restrictor, mixing tee, and reactor.

Post Column Pressure We add a post-column pressure gauge (Fig. 1-1) to determine if there is any blockages in the reactors. Note that the pressure in the post-column gauge is stable because it is down stream from the analytical column and the restrictors (i.e. standing down stream from the reservoir and dam in our earlier river example).

Now you are ready for Chapter 2.

Chapter 2

PCX5200 System Components

PCX5200 Post-column Instrument The PCX5200 is available for one-reagent or two-reagent, 120V or 240V operation, and is shipped completely assembled, calibrated, and tested.

The one-reagent PCX5200 consists of a simplex reagent pump, heated reactor, column heater, backflow and over-pressure safety devices, filters and flow conditioner, reagent reservoir, Saran® gas tubing, and other accessories. Note that the one-reagent PCX5200 can be easily upgraded to the two-reagent PCX5200.

The two-reagent PCX5200 consists of a duplex reagent pump, heated and ambient reactors, column heater, backflow and over-pressure safety devices, filters and flow conditioners, reagent reservoirs, Saran gas tubing, and other accessories.

If this system was purchased to analyze for glufosinate, amino acids, carbamates, or glyphosate, you should have an appropriate column kit and chemistry manual for your application.

Getting to Know Your PCX5200 Terminologies—There are three removable front panels (Figure 2-1). From left to right, they are referred to as:

1. Post-column panel
2. Reagent 1 flow-conditioner panel
3. Reagent 2 flow-conditioner panel (if applicable)

- Front Panels**
- On the post-column panel, the post-column pressure gauge measures the liquid pressure at the first mixing tee. This is effectively the pressure on the heated reactor, ambient reactor, and detector. This gauge indicates pressure when liquid is flowing through the system.
 - The liquid connections to the pressure sensor are labelled “From LC Pump” and “To Injector.” The pressure sensor is part of the safety interlock system. The sensor requires 500 psi (35 bar) before the module can be enabled.
 - The liquid connection “From Injector” is also the pre-column filter. The filter element is a 0.5 µm frit (Cat. No. 3102-9042).
 -  Note: Only PEEK ferrules should be used to connect the tubing from the injector. This is because the filter is made of a soft PEEK material and a stainless steel ferrule will damage it.
 - “To Detector” bulkhead fitting should be connected to the detector with 0.010 inch (0.25 mm) ID tubing.
 - “Over Pressure Relief” is a safety relief valve that opens in case the post-column pressure reaches >500 psi (35 bar). This protects the soft fluorocarbon tubing of the reactors from rupture in the event of a blockage in the post-column system or other fault. Run a piece of tubing from this fitting to a clean dry beaker. Any evidence of liquid in this tubing indicates a fault condition.

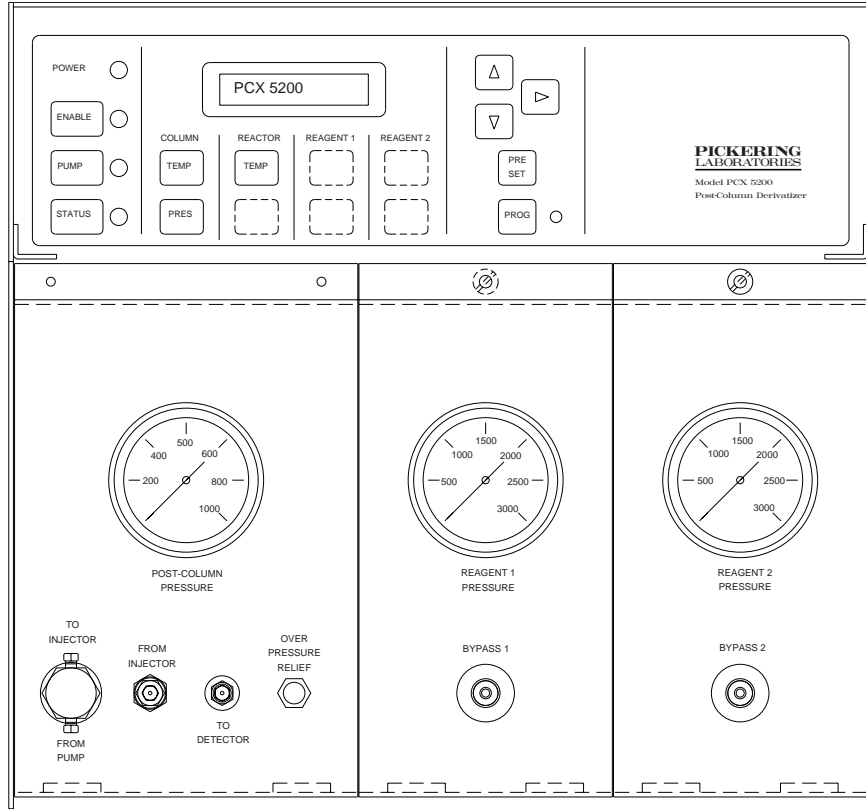

Figure 2-1. Front view of the two-reagent PCX5200 system

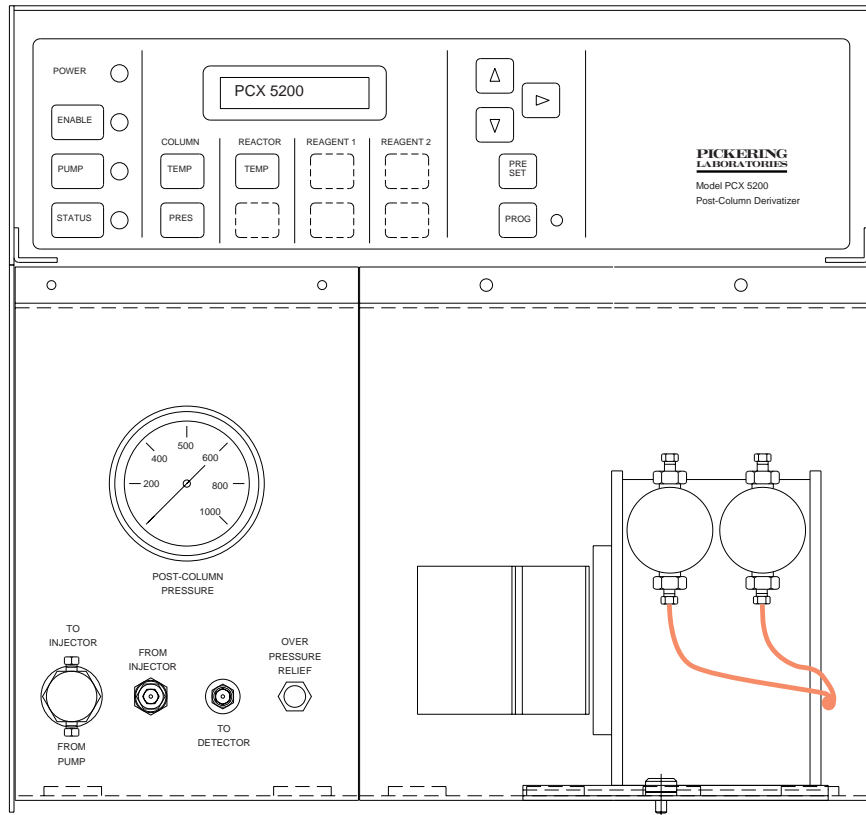

Figure 2-2 Exposed view of the two-reagent PCX5200 system and post-column pumps

- On the Reagent 1 flow-conditioner panel, the Reagent 1 pressure gauge measures the pressure of the reagent at the outlet of the reagent pump. This gauge is an integral part of the pulse-dampening system. When the reagent pump is on, the needle swings over a range of about 800 psi in time with the pump piston.
 - The “Bypass” 1 valve is used to purge and prime the first reagent pump. Attach the 20 mL syringe to the Luer fitting in the center of the knob. Open the valve by turning it counterclockwise about one turn. Apply suction with the syringe to draw reagent through the pump. Use strong suction to remove bubbles from the Reagent 1 pressure gauge, from the reagent pump, or from the reagent supply line. Close the valve by turning it clockwise; only gentle pressure is needed to close the valve. Keep the Luer fitting clean by rinsing it with water after use.
 - If applicable, the Reagent 2 pressure gauge operates the same as the Reagent 1 pressure gauge.
 - The “Bypass 2” valve is used to purge and prime the second reagent pump, and it operates the same as the Bypass 1 valve.
- Internal**
- The three removable front panels gives access to the liquid ends of the pump, reagent filters, restrictors, the thermostatted reactor, electrical connections for the reagent pump, and the flow adjustment knobs of the post-column pump. The two reagent panels can be removed by loosening the captive thumb-screws. The Post-column panel (left) can be removed by loosening the two captive thumb-screws.
 - The reagent pump with a piston-wash system is behind the two reagent flow-conditioner panels. In normal operation, the pump requires no adjustment. It is calibrated at the factory to 0.30 mL/min for both channels. The micrometer knobs on back of the pump adjust the flow rates. One full turn of the knob changes the flow rate by about 0.1 mL/min.



Important! Make sure the piston-wash system is flushed with 80/20 water/methanol before turning on the post-column pump.

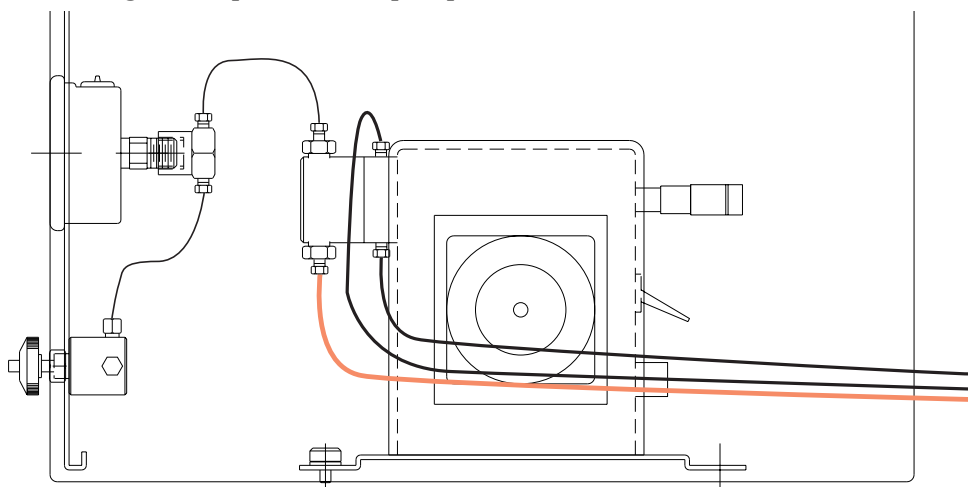

Figure 2-3.
Post-column pump &
piston-wash system

- The reagent filter is located just downstream of the prime/purge valve in the reagent panel. The filters and elements are similar in appearance to the pre-column filter, but they are different. The reagent filter element is a 2 μm frit (Cat. No. 3102-9040).

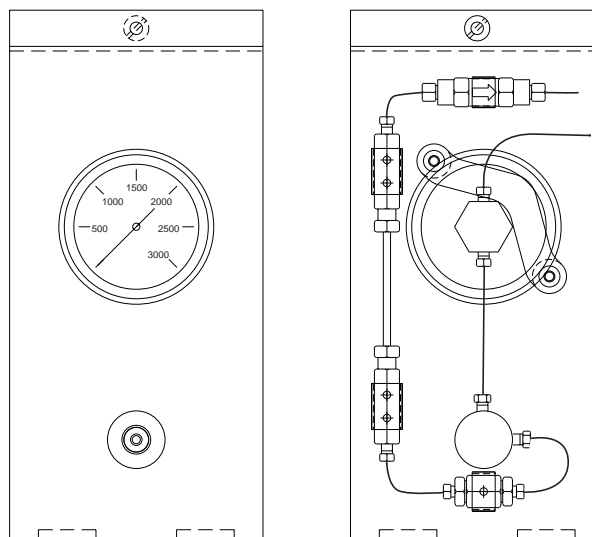

Figure 2-4.
Reagent filter &
flow-conditioner

- Rear Panel**
- The power connector is a standard IEC 320 type connector. Use the appropriate power cord for your local wall outlet and electrical code. The 120V version comes with a standard North American cord set. The 240V version comes with a cord set used in much of continental Europe (France, Germany, Benelux, etc.), or your local reseller may have provided the correct local cord set. If your local power outlets are different, you will need to obtain the appropriate grounded cord set.

- The main power switch is located in the power connector assembly.



- The fuse holder is located in the power connector assembly. To change the fuse, first remove the power cord from the connector. Carefully pry out the fuse clip with a small screwdriver. Replace with the specified-type fuse.

For 120 V systems, use a fast-acting 3 A, 250 V, 5 x 20 mm fuse, type GMA3 (Cat. No. 3543-0045).

For 240 V systems, use two fast-acting 1.6 A, 250 V, 5 x 20 mm fuses, meeting IEC127 specifications (Cat. No. 3543-0044).

- The serial computer interface is the DB9F connector. See the section later in this chapter about the “RS232 serial port.”



Warning. Ensure that the power cord is disconnected before replacing a fuse. Use only the specified-type fuse.

Attention. Assurez vous que le cable secteur n'est pas connecté avant de changer un fusible.

Warnung. Sicherungen dürfen nur bei nicht angeschlossenem Netzkabel ersetzt oder gewechselt werden.

Cuidado. Asegúrese que el cable de red está desconectado antes de instalar o cambiar un fusible.

Attenzione. Assicuratevi che il cavo di alimentazione sia scollegato prima di installare o sostituire un fusibile.

Waarschuwing. Zorg dat de voedingskabel losgekoppeld is, voordat een zekering wordt geplaatst of vervangen.

Avvertimento. Fare attenzione che la corda del voltaggio sia staccata prima di cambiare valvole. Usa solo valvole di capacità precisata dalla fattoria.

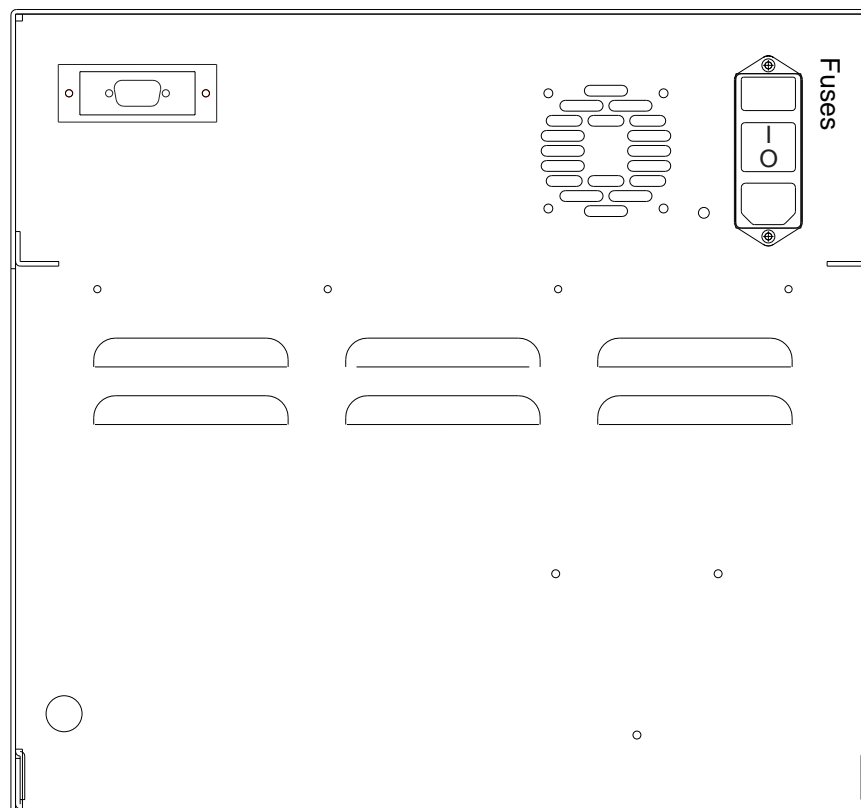
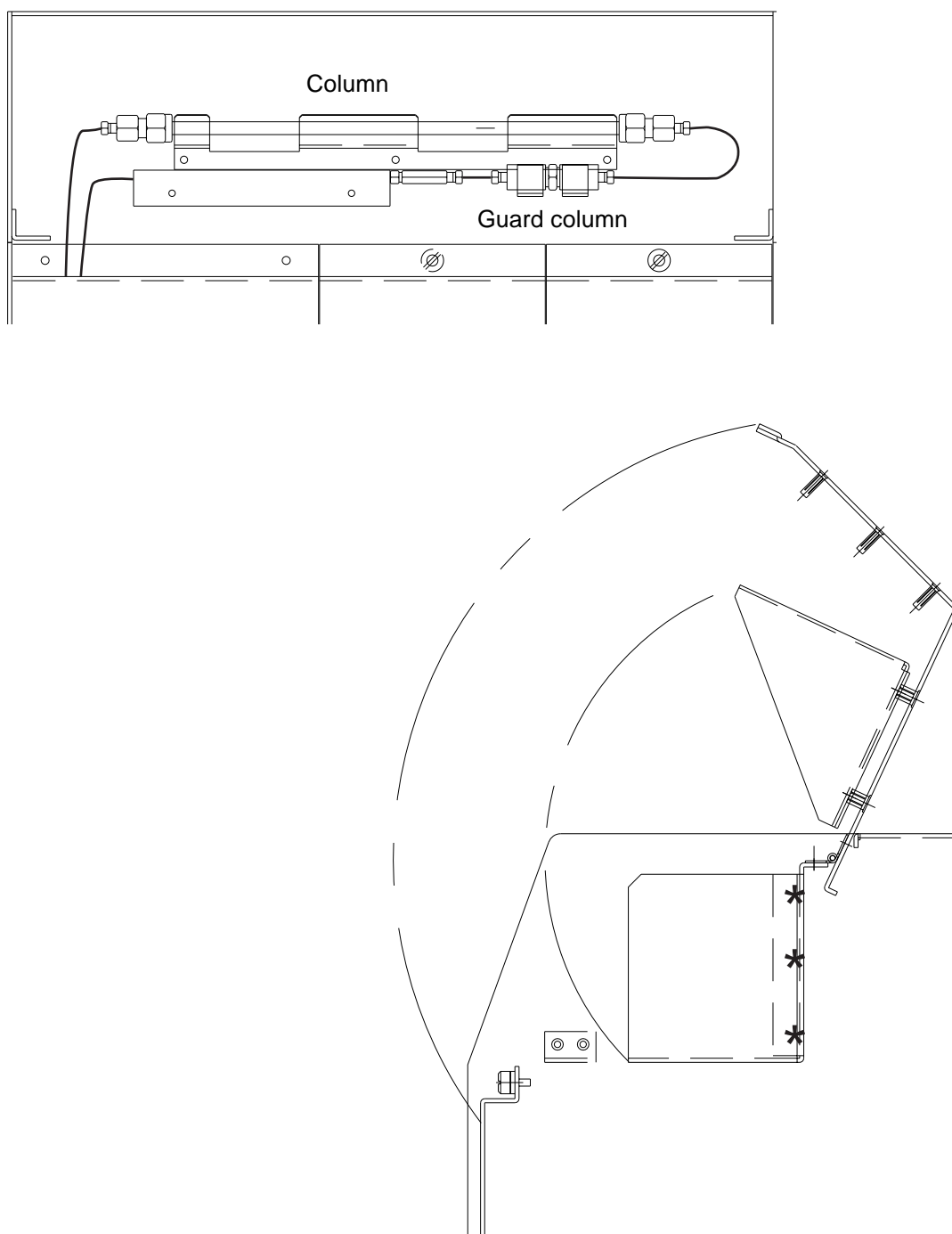

Figure 2-5. One fuse for 120V systems; two fuses for 240V systems

Column Oven The column oven is located in the front of the instrument. Simply lift the hinged lid to gain access to it. There is space for one analytical and guard column.

- The heater block is slotted to receive the analytical column (5, 10, 15, and 25 cm long).
- The last part of the lead-in capillary is embedded in the heating block to preheat the eluant for a more uniform temperature within the column. The lead-in capillary is 0.007 inch (0.17 mm) ID to minimize loss of efficiency.

Figure 2-6





Warning. The column heating block may become hotter than 70°C. For your safety, wear insulating gloves when the column oven is warm.

Attention. La résistance chauffante de la colonne peut dépasser une température de 70°C. Pour votre sécurité, prière de porter des gants isolants lorsque le four de la colonne est chaud.

Warnung! Der Heizblock des Säulenofens könnte heißer als 70°C werden. Für Ihre Sicherheit sollten Sie isolierende Handschuhe tragen, wenn der Säulenofen warm ist.

Atención. El bloque calefactor de columnas puede estar por encima de 70°C. Para su seguridad use guantes aislantes cuando el horno de columnas esté caliente.

Avvertimento. Il blocco della colonna potrà diventare molto caldo e superare ai 70°C. Per la sua protezione usa guanti con insulazione per questa applicazione.

Reagent Reservoirs The PCX5200 includes one pressurized reagent reservoir for the one-reagent system and two for the two-reagent system.



Warning. For your safety, the bottles are coated with a tough plastic film and are rated to a maximum of 15 psig (1 bar). Do not use uncoated bottles.

Attention. Pour votre sécurité, les bouteilles sont recouvertes d'un film de plastique dur, et sont calibrées à un maximum de 15 psig (1 bar). Ne pas utiliser les bouteilles non recouvertes.

Warnung! Für Ihre Sicherheit wurden die Reagenzienflaschen mit einem festen Schutzüberzug aus Kunststoff versehen. Die Flaschen sind bis max. 1 bar (15 psig) zugelassen. Flaschen mit beschädigtem Schutzüberzug dürfen nicht mehr benutzt werden. Verwenden Sie keine Flaschen ohne Schutzüberzug!

Atención. Para su seguridad, las botellas están recubiertas con una resistente película plástica, y están constrastradas a 15 psig (1 bar). No utilice botellas sin recubrimiento.

Avvertimento. Per la sua protezione, le bottiglie sono costruite forti con un percentuale du plastica, e sono usabili per un massimo di una Bar (15 psi). Non usare bottiglie normali.

- The “Gas Inlet” fitting is where inert gas enters the external gas regulator for pressurizing the reagent reservoirs (Figure 2-8). The gas regulator requires an input

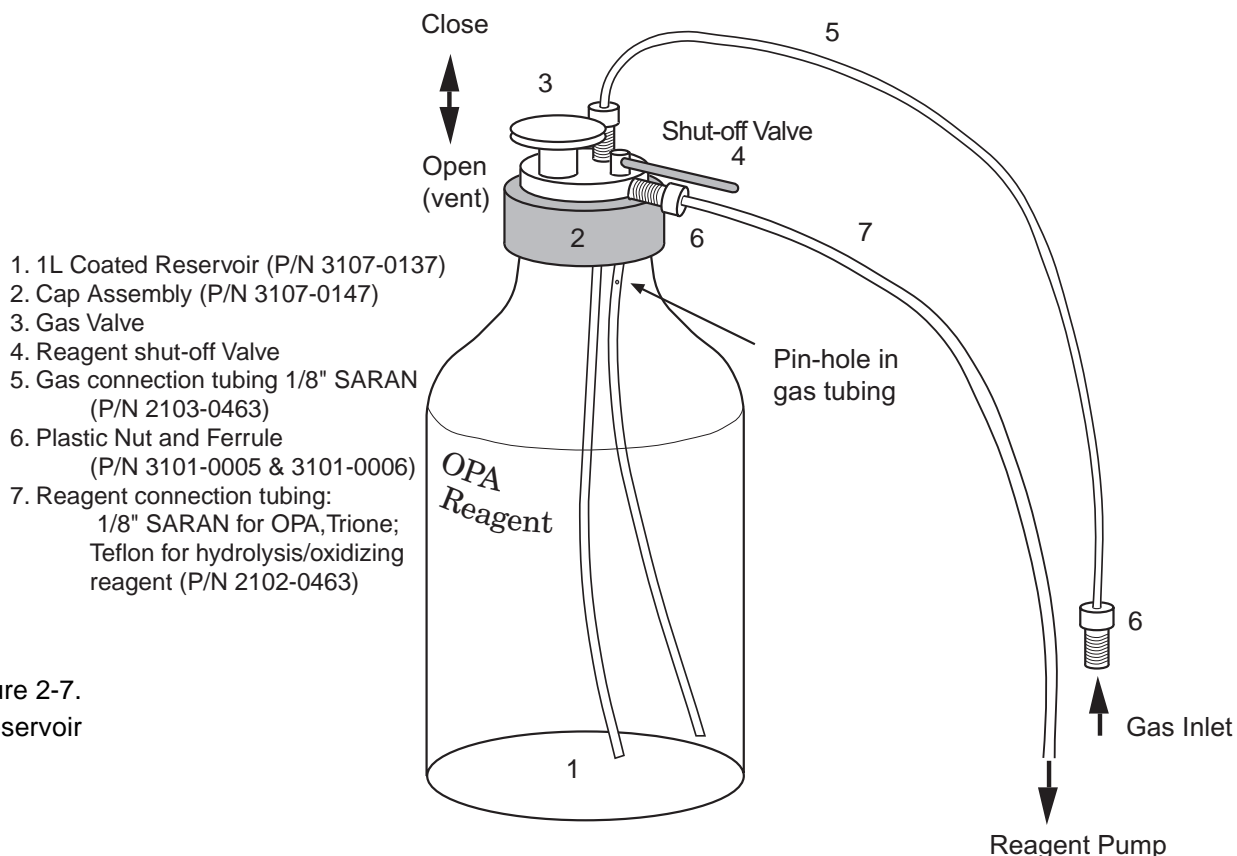

Figure 2-7.
Reagent reservoir

External Reagent Pressurization System

- pressure of 45–75 psi (3–5 bar) to function properly.
- Gas is controlled by the toggle valve. Lever ON pressurizes the manifold.
 - The gas manifold is more than a simple distribution block. Each outlet has its own check-valve to prevent back-flow of gas from the pressurized reagent bottles. The manifold also has a safety relief valve that opens at about 12 psi to prevent dangerous over-pressurizing of the reagent reservoirs. If the input pressure of gas is too low, the regulator sticks open and allows the gas to vent from the relief valve, rapidly depleting a gas cylinder.
 - Gas tubing for all reservoirs are 1/8" OD Saran tubing. Just under the cap there is a pinhole drilled in the gas tubing to prevent liquid from creeping up the gas line in case of a slow leak in the gas system. Connect the gas tubing to the gas manifold using 1/4-28 nuts and reversed-ferrules.
 - Reagent tubing is pre-connected to the pump at the factory. The protruding tubing from the rear of the PCX5200 should be connected to the reagent bottle cap directly facing the shut-off valve. Connect the Trione ninhydrin or OPA reagent to the Saran tubing and connect the Hydrolysis or Oxidizing reagent to the Teflon tubing. Nuts and reversed-ferrules (1/4-28) are provided.
 - The reservoir cap has a built-in vent valve. The large white knob is the valve; pull it up for CLOSED, and push it down for OPEN. If the gas is turned on, opening the vent valve will sparge the reagent. Closing the valve will pressurize the reservoir; this is the normal operating position. On the side of the cap, away from the on-off valve, there is a 1/4-28 fitting; you may optionally connect a tube here to carry vapors to an exhaust vent.
 - When changing reagent, first turn off the gas using the toggle valve on the manifold. Then vent the reagent bottle by pushing down the valve. Now you can safely remove the cap. It is convenient to have extra bottles so that you can simply transfer the cap without setting it down and risking contamination.

The keypad and liquid crystal display (LCD) user interface instructions are in three complementary parts. The first part is a general description of the keys and their

Figure 2-8. Gas Pressure System

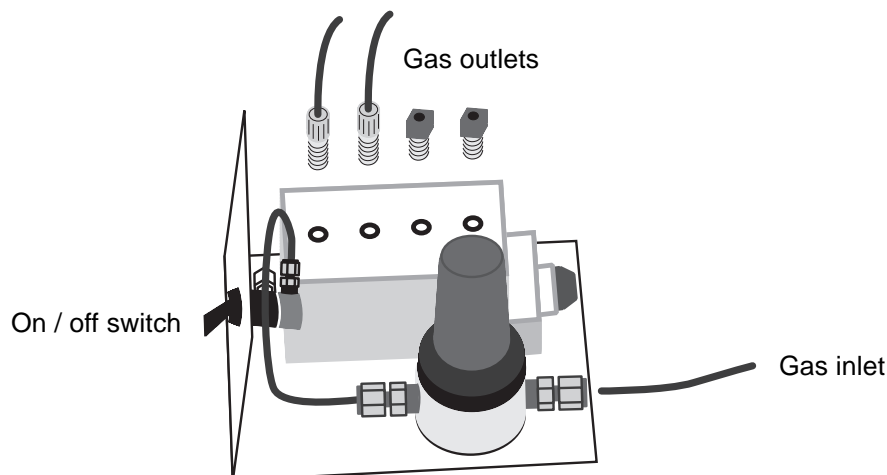

Keypad and Liquid Crystal Display User Interface

functions; the second part is comprised of examples; the third part shows diagrams.

The keypad has eleven keys, five LEDs, and a liquid crystal display. For routine operation of the instrument, there are preset parameters to get the system up and running in minimum time.

The keys can be divided into two groups:

1. Direct-acting keys: **ENABLE** and **PUMP** keys cause an immediate change of state without any other keys involved.
2. Status keys: The **COLUMN TEMP**, **COLUMN PRES**, **REACTOR TEMP**, **STATUS**, **PROG**, and **PRESET** keys all display the current status of that function when pressed. If the status message is a scrollable list, the first line ends in “...” to cue the user. To select a menu item, just press that key. To adjust a setpoint, press and hold that function key and use the Δ or ∇ key; menu selection takes effect when the function key is released. To reach the advanced options menus, hold a function key and press the **PROG** key.

The following table summarizes the keypad behavior.

- **POWER** indicator light (LED) is useful as an indicator that the PCX5200 is connected to a power source and the on/off switch on the back of the PCX5200 is turned on.

Key	Press	Hold	Hold & press PROG key
ENABLE	Toggle enabled state	—	—
PUMP	Toggle pump power	—	—
STATUS	Display ready/not ready/ alarm status. Scrollable list of conditions; elapsed service time	—	Reset elapsed time for pump
COLUMN TEMP	Display current temperature	Display setpoint; adjust with Δ or ∇ key	Interlock option, PID, sensor calibrations
COLUMN PRES	Display current pressure	—	Sensor calibrations; over and under pressure
REACTOR TEMP	Display current temperature	Display setpoint; adjust with Δ or ∇ key	PID, sensor calibrations
PRESET	Display # and name of current preset program	Load one of 5 presets with Δ or ∇ key	Save current settings as a preset; edit name, erase preset
PROG	Display scrollable list of s/n, date of manufacture, version #	—	—

- **ENABLE** key enables the power to the heated reactor and column oven.

The interlock system requires the pressure switch to sense over 35 bar (500 psi) before the PCX5200 can be enabled. This means that the LC pump must be running before “pressing **ENABLE**” can start the PCX5200. When enabled, the **ENABLE LED** turns green.

- **PUMP** key controls power to the reagent pump. To power the pump, the **ENABLE LED** must be green. The **PUMP LED** turns green when the pump is on.
- Pressing the **COLUMN TEMP** key shows the process temperature of the column oven to the nearest degree and one of the three signs: <, =, and >; indicating that the process temperature is less than, equal to, or greater than the set temperature, respectively. A * flashing indicates the column is heating.
- Pressing and holding the **COLUMN TEMP** key shows the set temperature of the column oven. To change the setpoint, press and hold the **COLUMN TEMP** key, and press the Δ key to increase or press the ∇ key to decrease.
- Pressing the **REACTOR TEMP** key shows the process temperature of the reactor to the nearest degree and one of the three signs: <, =, and >; indicating that the process temperature is less than, equal to, or greater than the set temperature, respectively. A * flashing indicates the reactor is heating.
- Pressing and holding the **REACTOR TEMP** key shows the set temperature of the reactor. To change the setpoint, press and hold the **REACTOR TEMP** key, and press the Δ key to increase or press the ∇ key to decrease.
- The recommended maximum temperature for the column heater is 75°C. A thermal safety switch limits the heater at ca. 80°C.
- The recommended maximum temperature for the heated reactor is 130°C. Above this temperature the reaction coil begins to lose strength. A thermal safety switch limits the heater at ca. 150°C.

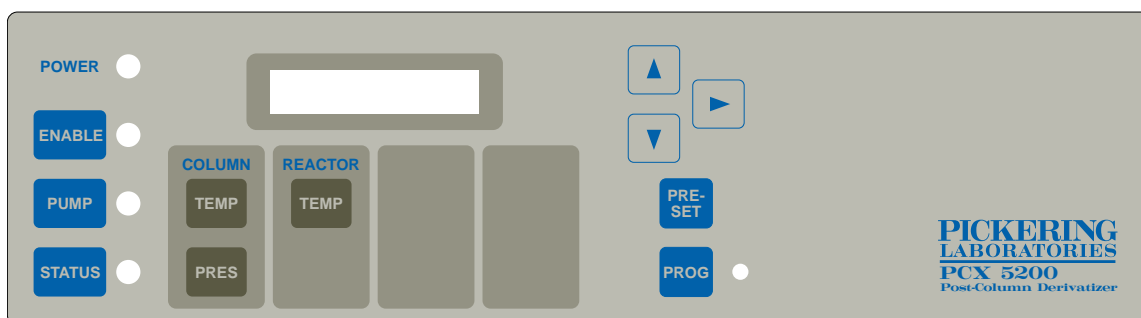

Figure 2-8. Keypad and LCD interface

- There are four LED status lights:
 - 1) POWER LED is green when the power cable is connected and the power switch is on.
 - 2) ENABLE LED

The ENABLE LED is orange when two conditions are fulfilled:

 - i) The LC column pressure is at least 500 psi (34 bar). The required LC column pressure to enable the PCX5200 is adjustable however, we recommend that this set pressure remains at 500 psi.
 - ii) The ENABLE key is not pressed.

It is green when two conditions are fulfilled:

 - i) The LC column pressure is at least 500 psi (34 bar).
 - ii) The ENABLE key has been pressed.
 - 3) PUMP LED is green when two conditions are fulfilled:
 - i) The PCX5200 is enabled.
 - ii) The PUMP key has been pressed.
 - 4) STATUS LED turns orange when the PCX5200 is enabled but the set temperatures are not ready or the post-column pump is off.

The STATUS LED turns green when the set temperatures are ready and the post-column pump is on.

The STATUS LED turns **red** if there is fault with the PCX5200

The following table summarizes the LED status.

Operational state	ENABLE LED	PUMP LED	STATUS LED
Enabled & Ready	green	green	green
Enabled & Not Ready	green	green or off	orange
Not Enabled	off or orange	off	off
Alarm	off	off	red

Keypad Examples Here are two examples to use the Keypad and Liquid Crystal Display User Interface

Loading a Preset A. How to start a routine Preset Analysis.

In this example, we will load a Preset program—Program 2 (named Glyphosate); enable the PCX5200; and then turn on the post-column pump.

1. Turn on main power switch in the back of the PCX5200;
The POWER LED light turns green.
The ENABLE LED is off.
The PUMP LED is off.
The STATUS LED is off.
2. Press and hold the PRESET key; the LCD shows: “Load preset...”
3. While holding down the PRESET key, press the ∇ key; the LCD shows: “# L Name of program”; for example Program number 1 is Carbamate, the LCD then shows “1 L Carbamate”. The letter L stands for Load. Of course, in this example, we want to use Program 2. With the PRESET key still held down, press the ∇ key a second time, the LCD will now shows “2 L Glyphosate”. Release the PRESET key.

 Note: there are five preset programs. Pressing the ∇ key (while holding the PRESET key) each time will change to the next preset program. Of course, by pressing the Δ key instead of the ∇ key, you could go back to the previous preset program.

These 3a–d steps are optional but it will help you to familiarize with other functions.

- 3a. Press the column TEMP key; the LCD displays the current temperature of the column oven: “Column ##°C <*”. The < sign indicates that the temperature of the column oven is below that of the set point. When the temperature of the column oven reaches the set point, the sign will change to an = sign. If it is above the set point, it becomes a > sign. The flashing * sign indicates that the column oven is heating up.

 Note: the column oven warms up automatically in the Glyphosate and Amino Acids methods (without enabling the PCX5200). The column oven does not warm up automatically in the Carbamates application. By default, the power to the column oven is controlled by the ENABLE function. However the power cutoff to the column oven can be overridden so that the column oven remains on independent of the ENABLE function. We will learn how to change this function in a later example.

- 3b. Optional. Press and hold the COLUMN TEMP key; the LCD displays the set temperature of the column oven: "Column set ##°C". In this example, it is 55°C.
- 3c. Optional. The REACTOR TEMP key operates the same way as the COLUMN TEMP key. Press the REACTOR TEMP key; the LCD displays the current temperature of the heated reactor: "Reactor ###°C <". Press and hold the REACTOR TEMP key; the LCD displays the set temperature of the heated reactor: "Reactor set ###°C". By default, the power to the heated reactor is controlled by the ENABLE function and cannot be overridden.
- 3d. Optional. Press the COLUMN PRES key; the LCD displays the current pressure of the HPLC column: "Column ### bar<". The < sign indicates that the HPLC column pressure is below the minimum pressure for the PCX5200 to be Enabled. This function was described earlier as the pressure-interlock system to protect the column from reagent back-flow. The minimum and maximum pressures for the pressure-interlock system were preset at Pickering Laboratories and we do not recommend any changes.

Press and hold the COLUMN PRES key. While holding the COLUMN PRES key, press the PROG key; the LCD displays the maximum pressure: "Pres Max 260 bar"; the PROG LED turns orange. To change the maximum pressure, press and hold the PROG key. While holding the PROG key, press the Δ or ∇ key to change the pressure (we do not recommend any changes).

Press the ∇ key; the LCD displays the minimum pressure: "Pres Min 32 bar"; To change the minimum pressure, press and hold the PROG key. While holding the PROG key, press the Δ or ∇ key to change the pressure (we do not recommend any changes).

Press the ∇ key; the LCD displays: "Set Autozero..." To autozero the pressure-sensor (make sure that the HPLC and post-column pumps are off), press the PROG key; the LCD displays: "Autozero? NO". Press the Δ key; the LCD displays: "Autozero? YES". Press the PROG key (note that the PROG key acts like an "ENTER" key when the LCD displays a choice of YES or NO). The LCD re-displays: "Set Autozero..."

Press the ∇ key; the LCD displays: "Pres Span 1710".

Press the ∇ key; the LCD displays: "Back? YES". Press the PROG key to exit; the LCD displays: "Column ### bar<".

Note: Before the last exit step, by pressing the Δ key instead of the ∇ key, you could go back to the previous step.

4. With the HPLC on at 0.4 mL/min, wait for the enable LED to turn orange, then press

the ENABLE key.
The POWER LED remains green.
The ENABLE LED turns green.
The PUMP LED is off.
The STATUS LED turns orange.

5. Once the temperatures of the heated reactor and column oven reach their set-points, press the PUMP key.
The POWER LED remains green.
The ENABLE LED remains green.
The PUMP LED turns green.
The STATUS LED turns green.

Congratulations! The system is ready to go (of course, it should be equilibrated for at least 15 min before your first injection).

B. How to save new conditions as a Preset program.

Saving a Preset

In this example, we will change the conditions of an un-named Preset program—Program 5—to a hypothetical Na amino acid program with sodium hypochlorite and OPA derivatizations. First let us review the parameters:

1. Column oven: 55°C
2. Column oven remains on at all time; i.e. not slaved to the pressure-interlock
3. Heated reactor: 36°C
4. Save as Preset program 5 and title it “Na AA OPA”

1. To adjust the set temperature of the column oven, press and hold the COLUMN TEMP key, and then press the Δ or ∇ key to obtain a readout of “Column set 55°C”.
2. Next, we want to set up the column oven to warm up automatically. By default, the power to the column oven is controlled by the ENABLE function.

Press and hold the COLUMN TEMP key, then press the PROG key; the LCD displays: “C PID...”

Press the ∇ key twice: the LCD displays: “C RTD...” first then would display “Set interlock...”



Press the PROG key to “Enter” the Set interlock function. Note this is also another example of the PROG key acting like an “Enter” key. The LCD displays: “Interlock ON”.

Press the ∇ key; the LCD displays: “Interlock OFF”.

Press the PROG key to “Exit” the Set interlock function.

Press the ∇ key; the LCD displays: "Back? YES".

Press the PROG key to "Exit" the Column oven programming functions; the LCD displays: "Save Changes NO".

Press the Δ key; the LCD displays: "Save Changes YES".

Press the PROG key to "Accept" the changes.

The LCD now displays: "Column ##°C<*" ". The flashing * symbol indicates that the column oven is heating up.

3. To adjust the set temperature of the heated reactor, press and hold the REACTOR TEMP key, and then press the Δ or ∇ key to obtain a readout of "Reactor set 36°C".

4. Press and hold the PRESET key and press the PROG key; the LCD shows: "Save preset..."

Press the PROG key to "Enter" the Save preset function; the LCD shows: "1 S Carbamate"

Since we do not want to write over this program, press the ∇ key until the LCD shows: "5 S".



Note that program 5 may or may not have a name assigned to it yet. If it is already in use, the LCD would show: "5 S name of program". If that is the case, press the Δ or ∇ key until the LCD shows just "# S". If all five preset programs are filled, you need to write over one of them. If you do not want to override any of the five preset programs, press the ∇ key until the LCD shows: "Back? YES" and press the PROG key to exit.

Press the PROG key to "save" the presently set conditions as a Preset Program. Once again, this step will override any previously set conditions for this particular Preset program. The LCD shows: "5 " with a flashing cursor after it.

Press the Δ key to choose the letter N.

Press the \triangleright key to move the flashing marker to the next space.

Press the Δ key to choose the letter a. Lower case characters come after the upper case characters.

Repeat until the desired name is completed: Na AA OPA. A space between words is allowed.

Press the PROG key to accept the name; the LCD shows: "Back? YES".

Press the PROG key to accept; the LCD shows: "Save Preset..."

Press the ∇ key three times; the LCD changes to: "Preset Name...", "Erase Preset...", and then "Back? YES".

Press the PROG key to accept; the LCD shows: "5 Na AA".

Program number 5 is now ready.

Flow Diagrams
PRESET Key

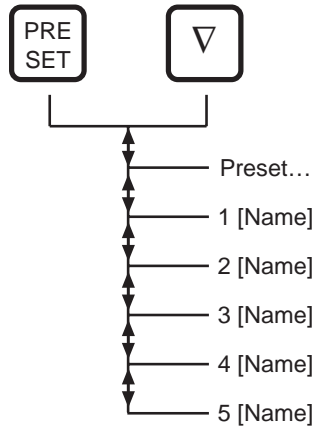

For all of the diagrams below, press and hold the function key (i.e. PRESET, TEMP), then press ▽ or PROG. For PROG functions, release the keys when the PROG LED turns orange.

PROG Key

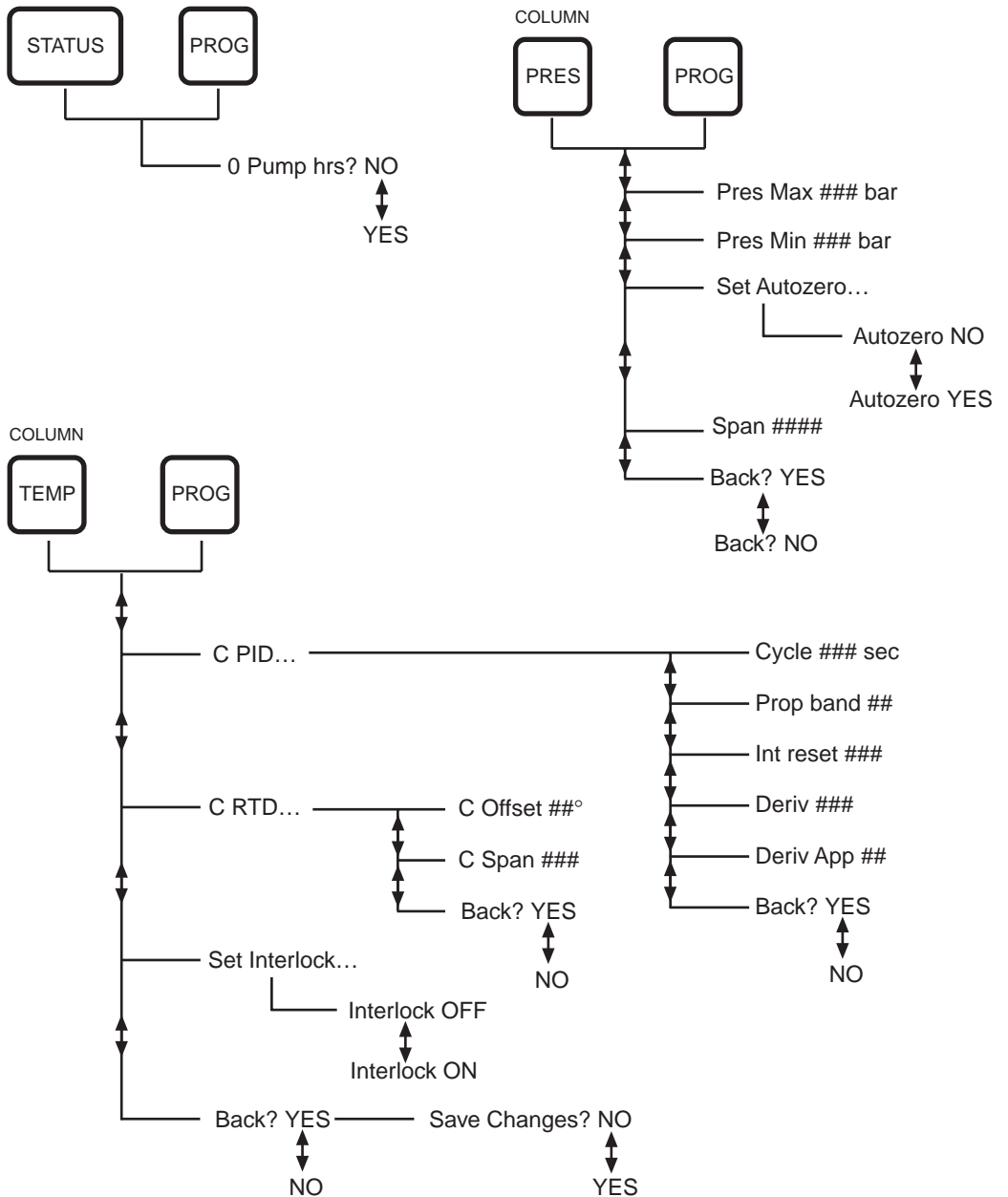

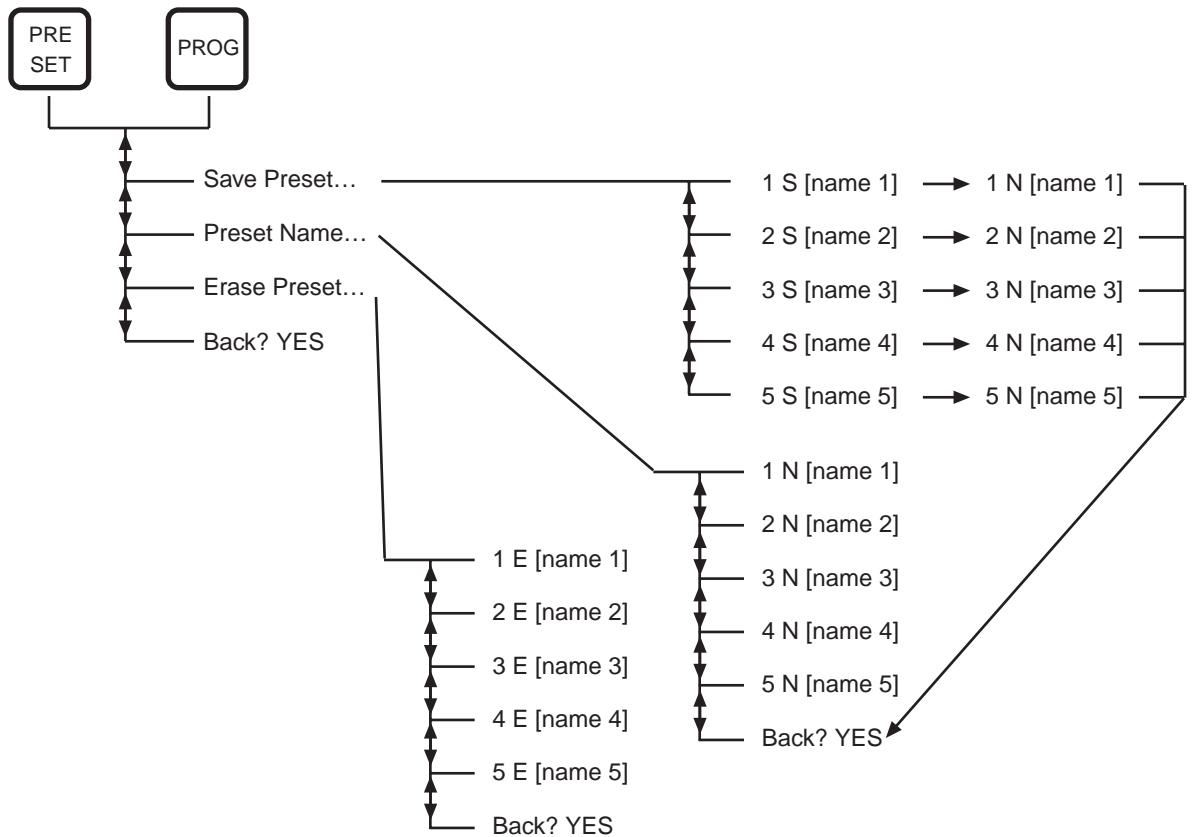
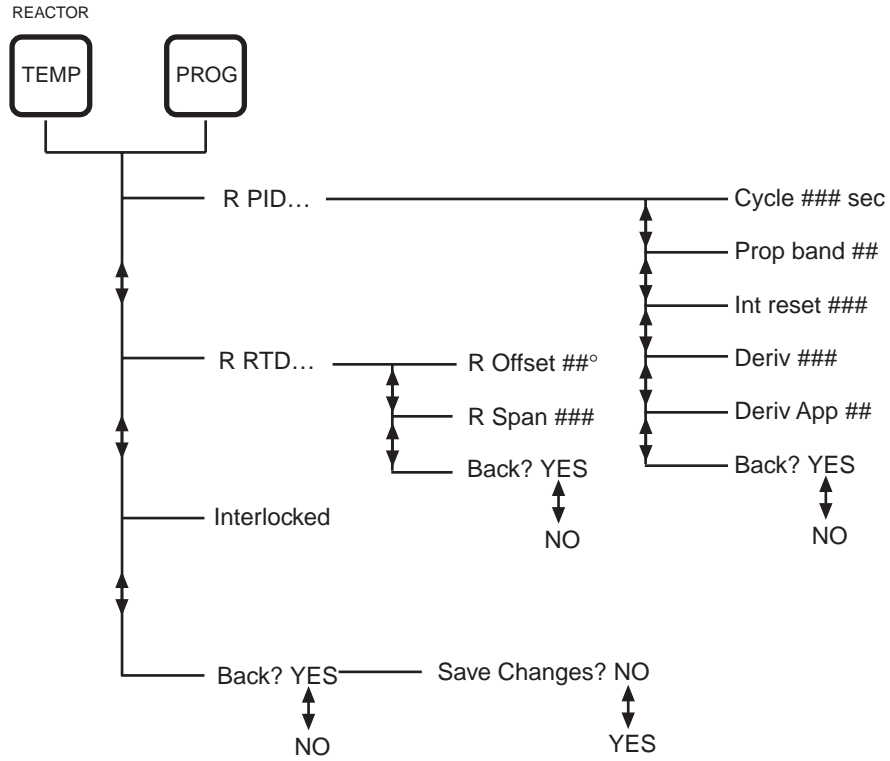

Specifications

Wetted Materials

PCX5200 316 Stainless steel
 17-4 PH Stainless steel
 Teflon FEP
 Saran PVDC
 Hastelloy-C
 Kel-F CTFE
 PEEK
 Viton
 Borosilicate glass
 Sapphire
 UHMW polyethylene

PCX5200 PEEK 316 Stainless steel
 17-4 PH Stainless steel
 Viton
 Teflon FEP
 Saran PVDC
 Kel-F CTFE
 PEEK
 Tefzel ETFE
 Borosilicate glass
 Sapphire
 UHMW polyethylene

Ratings Dimensions: 37 cm x 38 cm x 38 cm (h x w x d)
 Weight: 13 to 15 kg, depending on configuration
 Electrical Power: 100–120 V; 50/60 Hz; 1.7 A; 200 W; grounded supply; or
 200–240 V; 50/60 Hz; 0.8 A; 200 W; grounded supply
 Installation (overvoltage) category II, Pollution degree 2
 Environmental: Indoor use only
 Altitude up to 2,000 m (6500 ft)
 Ambient temperature 5–40°C (40-104°F)
 Relative humidity 80% @ 31°C, derated to 50% R.H. @ 40°C

RS232 Serial Port The RS232 serial port on the PCX5200 has three main purposes. The first is to allow your data system to communicate with the PCX5200. The second is to download presets and operating parameters to the EEPROM. The third is to download new system firmware into the flash memory. Pickering Laboratories does not provide software for your chromatography data system; you may write your own or use third-party software. For a complete description on the RS232 Port please contact Pickering Laboratories, Inc.

Downloading firmware Pickering Laboratories may announce free firmware bug-fixes or paid firmware enhancements. You may use a standard terminal emulation software to download the firmware file to the PCX5200. Instructions for how to do this will accompany the firmware package.

We need your comments to support the firmware. If you discover a bug, report it in writing to our Customer Service Department. We will also consider your written suggestions for new features or other enhancements.

Radio Frequency This device complies with Part 15 Class A of the FCC Rules. Operation is subject to the following two conditions: (1) This device may not cause harmful interference, and (2) this device must accept any interference received, including interference that may cause undesired operation.

External radio frequency interference may cause improper operation of the PCX5200. Such interference causes incorrect pressure measurements that may result in shutdown conditions. Remove the PCX5200 from the source of interference and reset the instrument; the PCX5200 will resume normal operation.

Chapter 3 Installation

Unpacking The PCX5200 instrument is shipped in one carton. Application Kits may be shipped in one or more cartons each. Report any carton damage to the carrier. Unpack all cartons and review the contents using the Packing List to ensure that your order is complete. If any items are missing, immediately contact Pickering Laboratories at (650) 694-6700 or by fax at (650) 968-0749.



Store any standards in the freezer/refrigerator immediately upon arrival.

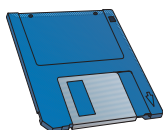

Complete and mail the warranty registration included in this manual to receive instrument method updates, and this User's Manual on Disk in Adobe Acrobat format.

Read all installation instructions and material safety data sheets (MSDS's) before operating your post-column derivatization instrument and HPLC system.

Site Requirements The HPLC pumping system, the injector or autosampler, the detector, and the integrator or data system must be supplied by the user.

HPLC System Requirements

- Binary or ternary gradient HPLC pump
For carbamate or glyphosate applications, the HPLC pump must be capable of binary gradient elution.

For amino acids or ALKION™ column applications, the HPLC pump must be capable of ternary gradient elution.

- HPLC manual injector or autosampler
The injector should be able to inject a 10 µL sample, preferably by full-loop injection. If drinking water is to be analyzed for carbamate insecticide residues, the injector should be able to inject at least 200 µL, and preferably 400 µL.



Important! If the system will be used for amino acids, glufosinate, glyphosate, polyamine, or diquat & paraquat analysis, be aware that the column regenerant is strongly alkaline. Any polymers or other materials in the HPLC pump, injector, needle seat, and detector must be compatible. For example, the standard rotor seal in Rheodyne injector valves is Vespel® polyimide, which is not recommended at pH ≥ 9; a **Tefzel® or PEEK rotor seal must be installed.**

- HPLC absorbance or fluorescence detector
To prevent boiling in the heated reactor, Pickering provide an external back-pressure regulator that should be connected to the detector waste line. The pressure rating of the detector flowcell must be ≥ 110 psi (7.5 bar). If your detector flowcell is rated

lower, consult Pickering Laboratories.

- Integrator or data system
- Because the Trione ninhydrin and OPA reactions are extremely sensitive, the HPLC system must be thoroughly clean before using it with the PCX5200. Pay special attention to the cleanliness of eluant reservoirs and delivery tubings.

Space Requirements Space requirements for the entire HPLC system are determined by the brand of HPLC pump and detector in use. Minimum benchtop space required for the Pickering system is approximately 17 inches (42 cm) long by 17 inches (42 cm) deep.

Electrical Requirement In addition to the outlets required for the HPLC system, one grounded outlet will be needed.

Inert Gas Nitrogen, helium, or argon (in order of preference), is required to pressurize the reagent reservoir(s). The PCX5200 requires gas pressure of 45–75 psi (3–5 bar) at the gas inlet. An adaptor from the gas regulator to 1/8 inch OD tubing is required. To minimize oxidation of the Trione ninhydrin or OPA reagent, use oxygen-impermeable tubing for the entire gas supply line (Saran or metal).

Miscellaneous Supplies Unless the Installation and Training service has been purchased, the user will need to provide adequate lengths of capillary tubing to connect HPLC pump and injector to pressure sensor (0.010–0.020 inch ID), to detector inlet (0.010 inch ID), to detector outlet (0.010–0.020 inch ID), and to injector outlet (0.007–0.010 inch ID).

Chemistry The user also needs to check the chemistry requirement for the specific application.

Installation of the PCX5200 Placement of the LC system and detector can be on either side of the PCX5200. For most cases, it is best to place the LC system on the left side of the PCX5200. The connections for reagent lines are from the rear. The gas manifold and the reservoir(s) can be placed on top. The column oven is in the front of the instrument; the oven door swings up about 5 inches (12 cm).

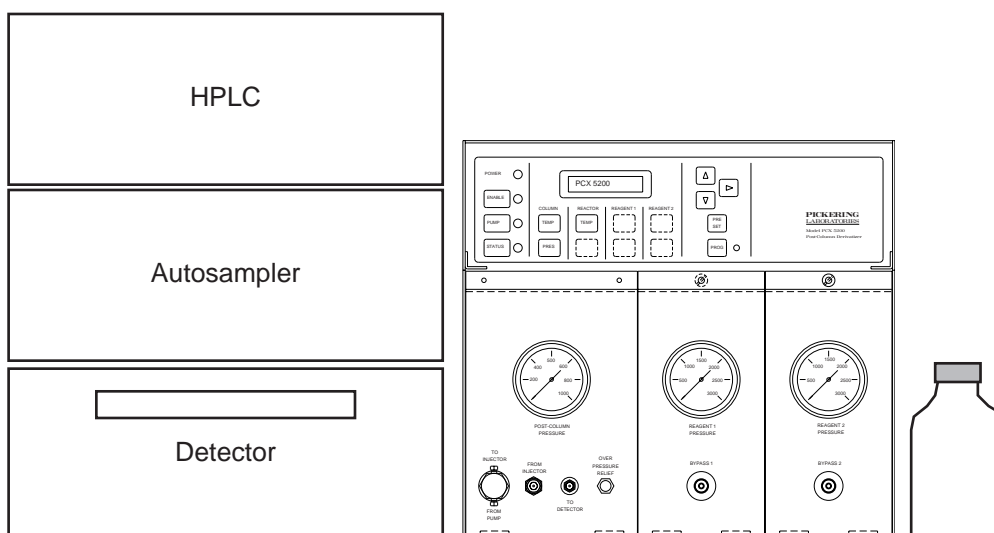

Figure 3-1

3-2

Note About The PCX5200 uses three styles of fittings.

- Fittings**
1. The high-pressure fittings are 10-32 x 1/16 inch Upchurch style. These fittings are compatible with Valco, Parker CPI, Swagelok, or various of the polymeric nuts and ferrules. The Valco Fittings can be indentified by a slightly longer fitting and in most cases, they are found in areas that are labled Valco (ex.restrictors).
 2. The low-pressure gas and reagent fittings are 1/4-28 x 1/8 inch size. These can be used with either flared fittings or reversed-ferrule fittings.
 3. The fittings for the over-pressure relief valve and external back-pressure regulator are 1/4-28 x 1/16 inch and use reversed-ferrule type fittings.

Pickering Laboratories supplies all the matching nuts and ferrules needed for normal assembly. Note that fittings and ferrules for the LC and detector are not supplied.



Upchurch, Parker, Valco style



1/4-28 reversed-ferrule

Figure 3-2. Note the direction of the ferrules: normal for Upchuch, Parker, & Valco; reversed for low-pressure 1/4-28.

- Inert Gas**
1. Using the 3m tan-colored 1/8 inch Saran tubing (PN 2103-0463) , connect the “Gas In” port on the external gas regulator to a supply of inert gas at 45–75 psi (3–5 bar). When using metal compression fittings, be careful not to over-tighten as the tubing can collapse or crack. Turn on the main gas supply. Switch the toggle valve to the ON position to start gas flow. Let the gas system purge for about one minute. Switch the toggle valve down to OFF.
 2. Using the 0.5m Saran tubing (PN 2103-0463), connect the reservoir to the gas outlet manifold. There are three fittings on each bottle cap; the gas tubing goes to the fitting on top of the bottle cap. Each of these tubings has a 1/4-28 nut and ferrule already in place. Plug any unused outlets of the manifold.



Note: Do not use polyolefin or fluorocarbon tubing. The Saran tubing is impermeable to oxygen and is used to prevent degradation of oxygen-sensitive reagents. Fluorocarbon tubing is 1,000 times more oxygen permeable than Saran tubing.

- Reagent Reservoir Connections**
1. Assume that new reservoirs have not been cleaned. Wash the bottle with laboratory detergent and hot water. Rinse with methanol then with deionized water. Wipe down the dip tubes on the caps with methanol and a clean, lint-free cellulose tissue. Avoid touching the tubings or the interior of the reservoir with your skin and do not leave caps and lines dangling without a reservoir because this will cause contamination.
 2. Connect the reagent line(s) from the rear of the PCX5200 to the reservoir(s). Connect the Trione ninhydrin or OPA reagent bottle to the Saran tubing. Connect the other

reagent to the Teflon tubing. Each of these tubings has a 1/4-28 nut and ferrule already in place. There are three fittings on each bottle cap; the reagent tubing goes to the fitting on the side of the bottle cap, facing the on/off valve.

 Note: Ensure that the reagent outlet and gas lines connected to an OPA or Trione reservoir are Saran (amber color). Saran tubing is necessary because of its low permeability to oxygen.

3. Optionally, place a small plastic container (in case of spills) on top of the PCX5200 and put the reservoir(s) in it.



Caution: The reagent bottles are specially coated with a protective polymer to ensure operator safety if the reservoirs should become over-pressurized. **Non-coated bottles must not be substituted in the PCX5200 system.** Replacement 1 L, 2 L, or 5 L reagent bottles may be ordered directly from Pickering Laboratories.

Pressure-interlock Connections

You may use either of two ways to connect the pressure sensor to the HPLC system.

1. Standard

1. Standard method for most applications and HPLC systems.

Using 1/16 inch x 0.020 inch ID capillary tubing, connect the outlet of the HPLC pump directly to the pressure sensor on the post-column panel. The connection is labelled "From Pump."

Using 1/16 inch x 0.020 inch ID capillary tubing, connect the pressure sensor to the inlet of the injector or autosampler. Use the fitting labelled "To Injector."

2. Alternate (for Amino Acids & others)

2. Alternate method for amino acid analysis with mobile phases with $\text{pH} \leq 3$ (to minimize corrosion of the sensor) or some integrated HPLC systems (to minimize tubing runs).

Use two pieces of 1/16 inch x 0.020 inch ID capillary tubing to connect a tee-fitting between the outlet of the HPLC pump and the inlet of the injector.

Use a third piece of 1/16 inch x 0.020 inch ID capillary tubing to connect the third port of the tee to the lower inlet of the pressure sensor on the post-column pressure panel, labelled "From Pump."

Install a high-pressure plug in the upper outlet of the pressure sensor, labelled "To Injector."

 Note on usage: The post-column interlock monitors the eluant pump pressure and turns OFF electrical power to the post-column reactor, reagent pump, and column oven, when the eluant pressure drops below 500 psig. (This pressure decrease may occur due to eluant pump malfunction, empty reservoirs, or a programmed shut-down after the last sample.) The interlock turns off the reagent pumps to prevent backflow of reagents into the column, which can ruin the column. The interlock also defaults to OFF when a power loss occurs. The PCX5200 instrument does not automatically turn on as the eluant pressure rises above 500 psi. Press the ENABLE button to enable the instrument.

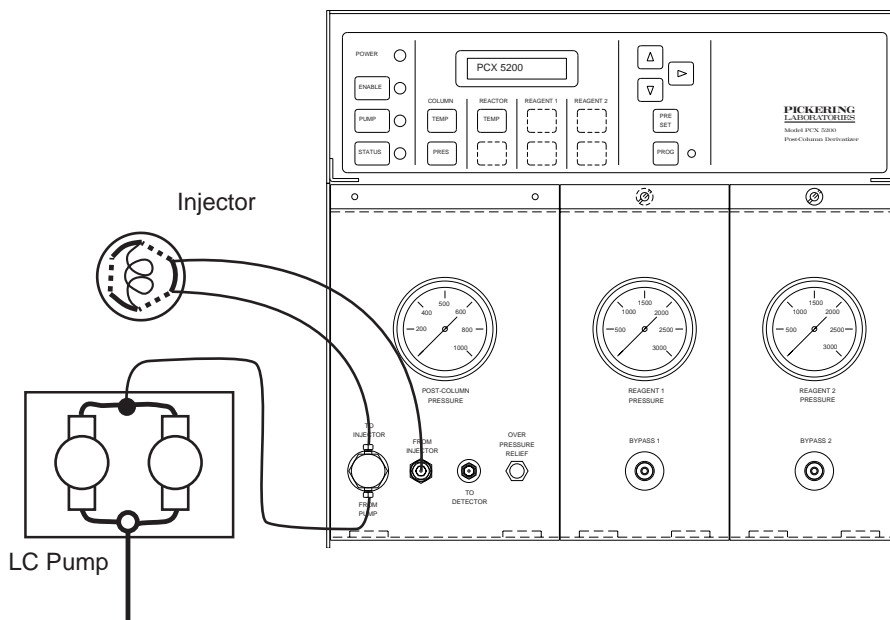

Standard method to connect the Pressure-interlock

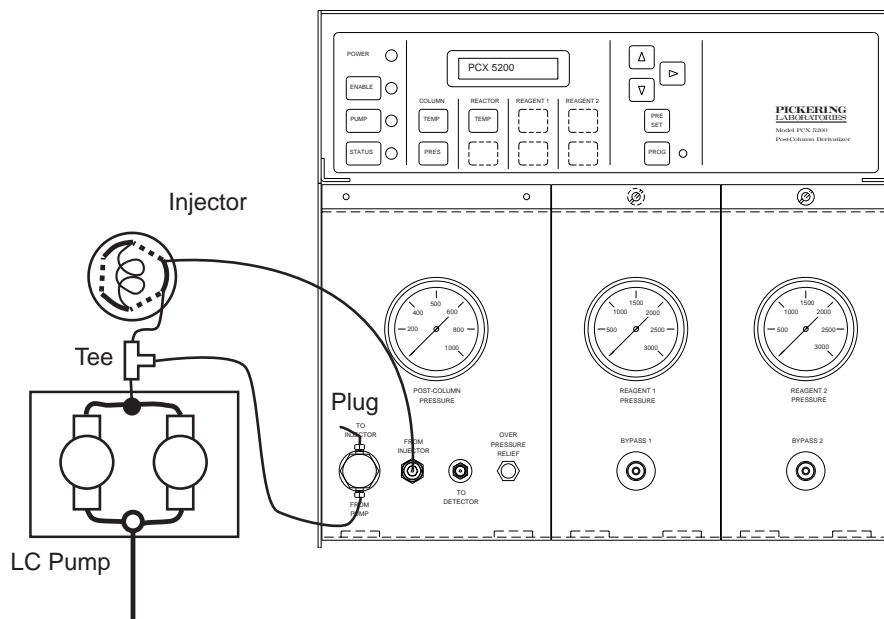

Alternate method to connect the Pressure-interlock—ideal for corrosive eluants

5 baaHowever, the default power-off to the column oven can be overridden so that the column oven remains on independent of the post-column interlock (Enable function).



1. **Caution!** Operating the reagent pumps when the HPLC pump is not producing eluant flow can pump reagent into the analytical column causing irreversible damage.
2. Maintaining high temperature in the post-column reactor when there is no HPLC eluant flow can cause precipitation and complete blockage of the post-column reactor.

Injector Connections Connect the outlet of the injector (or autosampler) to the bulkhead fitting labelled “From Injector.” Use 1/16 inch x 0.007 inch ID or 1/16 inch x 0.010 inch ID capillary tubing. This fitting contains a replaceable 0.5 µm filter element. The bulkhead fitting is made of PEEK; use the PEEK nut and ferrule that comes with the PCX5200 to avoid damaging the fitting.

Detector Connections

1. Install the HPLC detector referring to the manufacturer’s manual supplied with the instrument.
2. Connect the inlet of the detector flowcell to the bulkhead union labelled “To Detector.” Use 1/16 inch x 0.010 inch ID capillary tubing.



Note to Hewlett-Packard 1046A end-users: Replace the 0.12 mm ID inlet tubing (red) and heat-exchanger from the left side of the detector to the flowcell (behind the front panel of the detector) with a 0.25 mm ID tubing (HP Cat. No. 79881-67302 or Pickering Cat. No. 3110-6045; blue tubing) to reduce the back-pressure.

3. Connect a 1/16 inch x 0.020 inch ID tubing from the outlet of the flowcell to the external 100psi backpressure regulator using a 1/4-28 nut with a 1/16 inch reversed-ferrule.

Caution! The 100psi back-pressure regulator is directional. Do not reverse flow!



Caution! The back-pressure regulator provides 100 psi (7 bar) of back-pressure to the detector and prevents outgassing at the flowcell. The pressure rating of the flowcell must be at least 110 psi (8 bar) so that the flowcell is not damaged. If your detector has a flowcell pressure rating of less than 100 psi (7 bar), contact Pickering Laboratories. The minimum necessary backpressure is 75 psi (5 bar).

4. Connect a 0.020 inch ID PTFE tubing to the outlet of the external 100 psi back-pressure regulator. Place the other end in an appropriately labelled waste container.
5. Set the wavelengths of the detector as specified in the applications.
6. Set the time constant to 2–4 seconds.
7. Connect the signal cable from the detector to the input terminal of your data station. Ensure that the polarity is correct (refer to your HPLC instrument manual).

**Guard & Analytical
Column Installation**

1. A set of PEEK tubing is provided in the Application Kit for installing your Pickering column. Select the column that you wish to install, and the corresponding tubing set. Refer to Figure 3-3 for column placement and door operation.
2. Open the column oven door. Be careful not to knock off the reagent bottle(s) if they are placed on top of the PCX5200.
3. LOOSELY Connect the outlet of the guard column to the inlet of the analytical column.
4. Loosely fit the inlet of the guard column to the eluant heat exchanger. Carefully lay the analytical column into its slot in the heating block.
5. Turn on the HPLC pump at 0.2 ml/min at 100% of the column storage solution.
6. Wait for liquid to drip from the heat exchanger. Tighten the connection to the guard. Wait for liquid to drip from the inlet of the column and then tighten the connections.
7. A loose end of tubing with Fingertight™ fitting in the column oven leads to the first mixing tee. Attach the loose end to the outlet of the analytical column.
8. Close the column oven door.

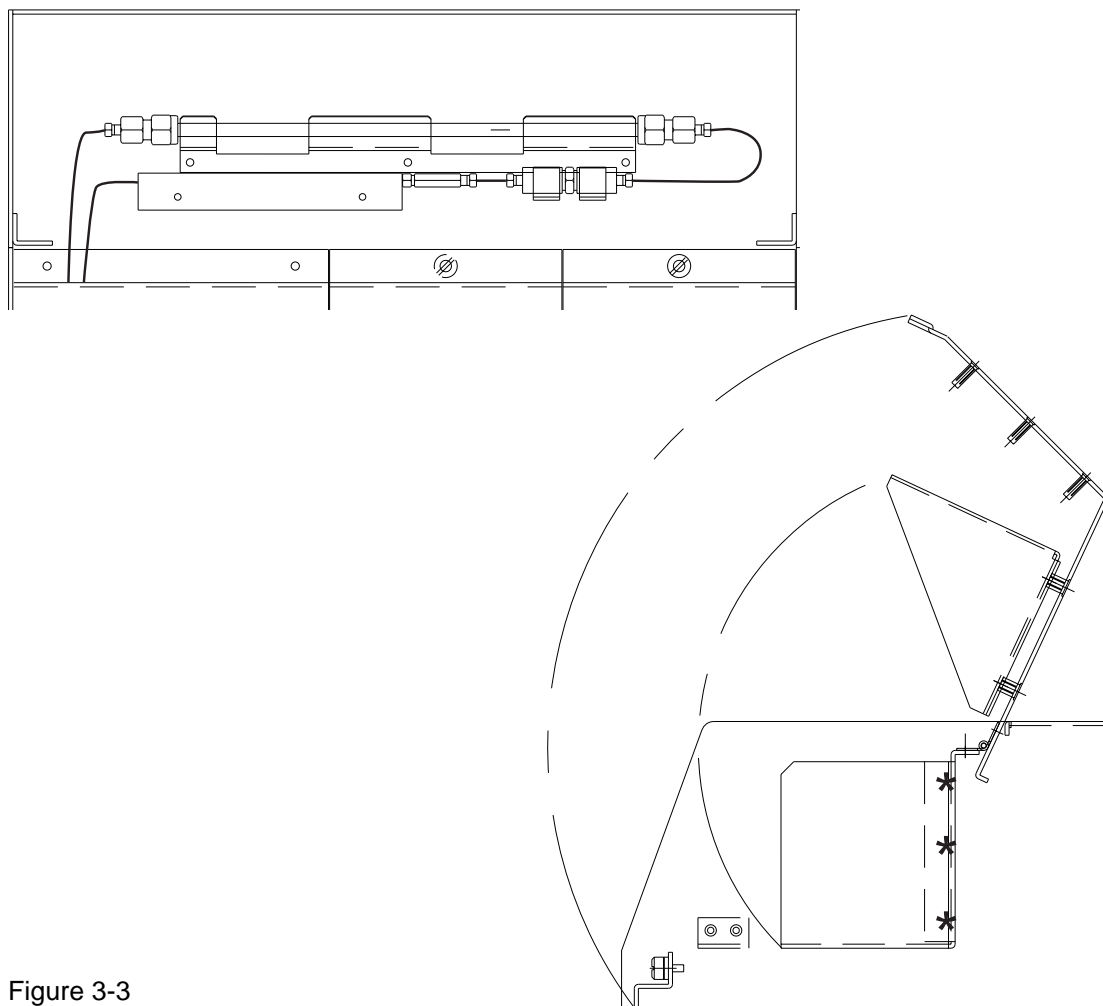

Figure 3-3

Reagent Pump The reagent pumps have been calibrated to 0.30 mL/min at the factory and should not need further adjustment.

Piston-wash System **Important!** Before starting the post-column pump, connect a syringe and flush the piston-wash system with 80:20 water:methanol (4 mL each time, at least twice a day). Alternatively, you may connect it in series with the piston seal-wash system on your HPLC so that you can flush them at the same time. The piston-wash system is designed to flush the back-end of the primary seal which significantly extends seal life. However, if a pump with a piston-wash system is used without liquid in the piston-wash system, the secondary seal will wear out quickly (because it is dry). It can then scratch the piston and the scratched piston will in turn cause the primary seal to fail.

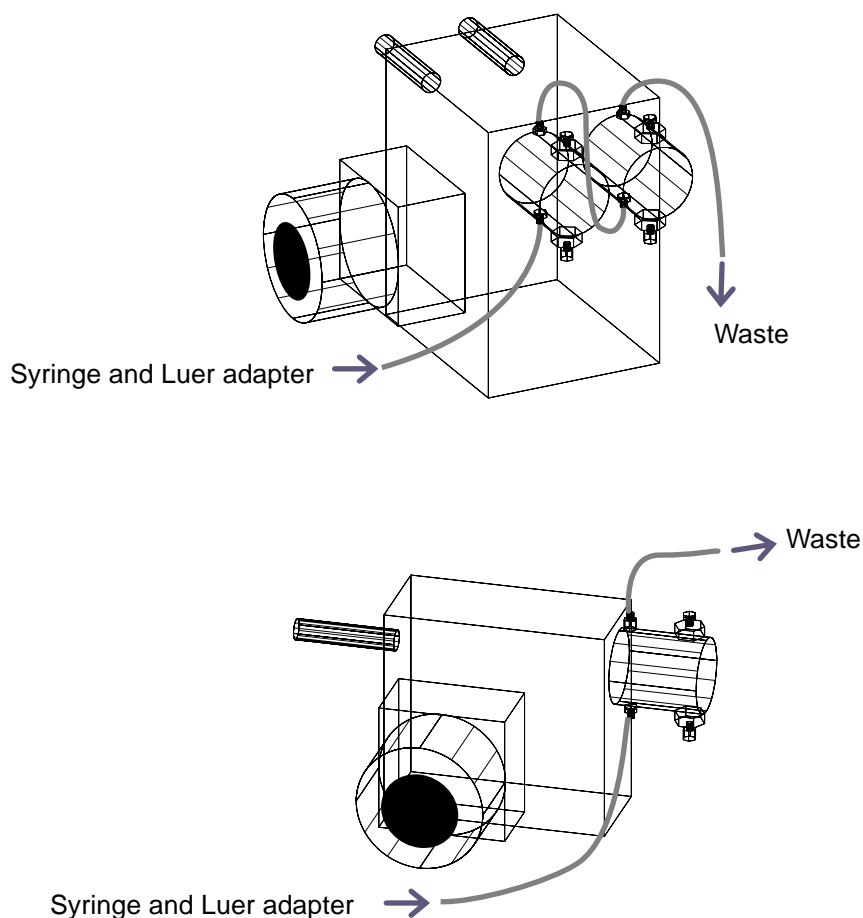

Figure 3-4

Priming the Reagent Pump

1. Ensure that the reagent and gas supply tubings are connected to their proper fittings on the reservoirs.
2. At the start, it is best to fill the reservoirs with methanol or a mixture of methanol/water.
3. Connect a 20 mL disposable syringe to the Luer fitting in the center of one of the prime/purge valves.
4. Open the prime/purge valve 1/2 to 1 full turn (CCW) and let the flow exit into the syringe.
5. To purge air bubbles from the reservoir line, pump head, or reagent gauge, syringe suction may be applied. Draw liquid until no bubbles come through.
6. Close the valve, remove the syringe, and wash the Luer fitting with a little water.
7. Repeat the process for the other valve (if applicable).

If priming the reagent pump is difficult, see Chapter 4 (p 4-13).

System Testing & Verification

Read the Application Manual (if applicable) to become familiar with the use of your instrument. In Chapter 4 of this manual, there are procedures for the initial system testing. The installation is not complete until the initial system tests have been performed satisfactorily.

The initial system tests consist of:

- Parameter log of pressures, temperatures, and flows under standard initial conditions (Appendix A)
- Chromatogram of test mix using Pickering standard conditions (if applicable)



Shutdown Important! If the system will not be used immediately after the installation, the system must be shut down properly. Generic shutdown procedures are given below but we advise you to follow the specific **shutdown procedures** in the Application Manual.

Upon completion of the analyses, use one of the following two procedures to shut down the PCX5200 system properly. These procedures can prevent potential column damage, reaction coil blockage, high background fluorescence, reagent precipitation, or other problems.

- Short-term (up to 3 days)**
1. Turn off the PCX5200 either manually by pressing the ENABLE key or via the “Slowdown” program (see below).
 2. Set the HPLC pump at the normal flow rate to flush the system for at least 20 minutes to allow the heated reactor to cool. Choose an eluant that elutes contaminants from the column; for example, methanol for a reversed-phase column and regenerant for an ion-exchange column.
 3. Set the HPLC pump to ≤ 0.1 mL/min.
 4. Turn off the detector lamp.

5. You may also program a slowdown method to accomplish all the above steps.

Step	Time (min)	% Eluant	Flow (mL/min)
0	0	100	0.02
1	5	100	0.02
2	5.1	100	Normal flow*
3	25	100	Normal flow*
4	25.1	100	0.02

(*) Normal flow rates are different for various columns. Follow the instructions that came with your column.

**Medium-term
(up to 6 days)**

1. Turn off the PCX5200 either manually by pressing the ENABLE key or via the “Slowdown” program.
2. Set the HPLC pump at the normal flow rate to flush the system for 30 minutes. Choose an eluant that elutes contaminants from the column.
3. Replace both reagents with water and draw 10 mL through each prime/purge valve.
4. Replace the water in the reagent reservoir with water / methanol (approximately 1/1).
5. Turn off the fluorescence detector and HPLC pump.
7. Loosen the fitting at the inlet of the 100 psi external back-pressure regulator, relieving pressure on the post-column system. Place paper towels under the back-pressure regulator to absorb any escaping liquid.
8. Relieve the pressure in the reagent gauges by briefly opening the bypass valves



Caution! The long term shutdown should be performed prior to any work on the HPLC or PCX5200. Failure to do so could defeat the safety systems.

**Long-term
(7 days or longer)**

1. Replace the reagent(s) with water and draw 10 mL through the prime/purge valve.
2. Set the HPLC pump at the normal flow rate. Choose an eluant that elutes contaminants from the column. Turn on the PCX5200 to flush the system for 15 minutes. Set the reactor temperature to $< 60^{\circ}\text{C}$.
3. Turn the reagent pump on and flush the entire system for 10 minutes.
4. Depressurize the system by disconnecting the "To Detector" fitting. Disconnect the outlet of the column and remove the column and guard. Plug them tightly.
5. Replace the column and guard with a restrictor or small ID tubing and unions so there are no open lines.
6. Remove any buffers from the HPLC and replace them with water.
7. Increase the flow rate of the HPLC to give 500 psi on the post-column system.
8. Flush the entire system for 30 minutes, then replace the water on the HPLC with 80/20 water/methanol.
9. Replace the water in the reagent reservoir with water / methanol (80/20).
10. Start the HPLC and reagents pumps, and flush the system for another 10 minutes.
11. Relieve the pressure in the reagent gauge(s) by briefly opening the bypass valve(s).
12. Let the system drain for 1–2 minutes.
13. Loosen the fitting at the inlet of the 100 psi external back-pressure regulator, relieving pressure on the post-column system. Place paper towels under the back-pressure regulator to absorb any escaping liquid.
14. Turn off the gas at the toggle valve of the gas manifold assembly and vent the reservoirs.
15. Turn off the main power of the PCX5200.
16. Turn off the HPLC system.
17. Turn off the inert gas source.

Chapter 4

Routine Maintenance & Troubleshooting

Your Pickering PCX5200 will require some routine maintenance to stay in top condition. Ordinarily, little maintenance is needed beyond good operating procedures. For example, keeping the back-side of the piston-wash system wet with a mixture of water / methanol significantly extends seal life.

Initial System Testing The initial system testing is part of the installation process. Part of this testing is to establish standard conditions so that you can return to them for diagnostic purposes in the event of later problems.

Test Chromatogram Set up the HPLC and the PCX5200 as required in the applications. Collect two chromatograms to be sure that the system is stable and repeatable. Compare your chromatograms to the test chromatogram supplied with the Pickering column. Your chromatograms should not be significantly different. If there is a problem, see the later portion of this section for troubleshooting. Keep copies of your test chromatograms and the Pickering test chromatogram on file.

Parameter Log Make copies of the blank forms in Appendix A and complete the parameter log on the photocopy. Your system should have come with a similar log from factory testing. Use the same conditions as for the test chromatogram above. Report the pressures for the system equilibrated under initial conditions. The pressures reported for Reagent 1 and Reagent 2 should be the maximum swings of the pointers. Although the parameters will not be identical to the factory, they should be similar. Keep a daily log of the four pressures for diagnostic use. See page 4-11: Interpretation of Pressures.

There is also a sheet for you to record the HPLC system parameters. Include all the settings for the pump, injector, detector, and integrator. Keep copies of this document as it will be very helpful for troubleshooting.

Typically your conditions for routine analysis will be different than the conditions used for testing. You may be using a different sample, sample volume, standard solution, gradient, or even column. Set up the system for injection of your calibration solution, and collect two chromatograms. The only standard for comparison is your expectations.

Fill out the parameter log for your initial conditions if they are different than the Pickering standard conditions. Record all the LC settings for your method.

Keep copies of these chromatograms and logs for future use. We suggest posting this information near your instrument.

Precautions & Problem Prevention

- Use Pickering Laboratories reagents and eluants. The quality of the chemicals is excellent and the cost is low relative to the worth of your analytical results. The one year warranty does not cover damage caused by poor-quality reagents and eluants not purchased from Pickering Laboratories.
- Use the proper start-up and shutdown procedures consistently (see Chapter 1).
- Frequently observe the pressures and check for leaks. You should be able to identify a problem before it becomes serious. Keep a daily log of the four pressures.

Mobile Phase

- Avoid touching the interior of the mobile phase reservoirs and the dip tubes with your fingers. Amino acids in fingerprints will cause contamination. Gloves are suggested.
- Do not leave caps and lines dangling without a reservoir. To fill reservoir, transfer caps and lines into a spare bottle or an Erlenmeyer flask filled with deionized water.

Back-flow Prevention

The PCX5200 has two safety systems to prevent accidental backflow of reagents onto the column. The pressure interlock requires that the HPLC pump deliver at least 500psi (35 bar) before the reagent pump can be engaged. The second is a pair of automatic valves that prevent gas pressure from pumping reagents back through the column during extended shutdowns. However, there are ways that the safety systems can be bypassed accidentally. For example, residual pressure in the gauges immediately after shutdown will take some time to leak down to zero. Follow these procedures to avoid such accidents:



- **Never** disconnect any fittings between the HPLC pump and the column until the post-column system has been shut down and **depressurized** (loosen the “to detector” fitting).
- Any leaky fittings between the HPLC pump and the column can permit backflow in the event of an unattended shutdown.
- When removing the column, remove the **outlet** fitting **first**.
- Always follow the proper shutdown procedures. See Chapter 1.

Reactor Precautions

- Do not operate the heated reactor above the boiling point of the eluant unless the external 100 psi back-pressure regulator is connected to the waste line of the detector. Boiling inside the reactor causes precipitates to form.
- Do not operate the reactor above 130°C. This can weaken and deform the PTFE tubing.
- Do not operate with a post-column pressure above 600 psi.

Electrical Precaution

- Always use the correct fuse.

**Routine
Maintenance
Reagent Pump**

The PCX5200 uses a custom-made Eldex reagent pump with piston wash. The piston seals require periodic replacement. The length of service to be expected from the seal depends on a wide variety of factors, including whether proper shutdown procedures were followed, how often the system was turned on and off, and whether the piston-wash system was wetted. It is critically important that the seal be replaced immediately upon failure, or better yet, before failure, because the reagent can leak into the mechanical housing of the pump and cause corrosion. When a leak occurs, you may notice fluid on the side of the pump. However, a leak may not always be visible, particularly at slow flow rates. A litmus paper can be placed in the drain slot (both sides of the pump); the litmus paper should be removed periodically and checked for color changes to see if leakage has occurred.



If you have the piston seal wash feature, and the pump pressure exceeds 2500 psi for more than a couple minutes, the high-pressure piston seal will deform, and start to leak. After you have corrected the high-pressure situation, replace the piston seal.

**Pump Seal
Replacement**

You will need to purchase a seal kit (3106-1310; including two seals, two back-up washers, a 5/32" hex wrench, and a seal installation tool). Extra seals and a preventive maintenance kit may also be ordered from Pickering Laboratories (see Appendix B). Additional tools needed for piston seal change are 1/4" and 1/2" open-end wrench. Open-end wrenches can be purchased at local hardware stores.

1. Flush the Eldex pump with water, then shut down the PCX5200, and let the reactor cool. Turn off the gas valve and vent the reservoirs. Turn off the integrated 2-way valve on the reservoir cap.
2. Open the column oven.
3. Remove the flow conditioner panels (center and right) by loosening the captive screws. Remove one flow conditioner at a time. After removing the captive screw, flip the flow conditioner upside down and place it behind the louver (in front of the column oven). You do not need to disconnect any tubings yet. Repeat the same procedures for the second flow conditioner panel.
4. Disconnect the reagent inlet line from the bottom of the pump head. Wipe up any spilled liquid. Disconnect the outlet tubing from the top of the pump head (stabilize the outlet check-valve with a 1/2" wrench when removing the 1/16" fitting to prevent the check-valve from moving).

5. Remove the pump from the chassis by 1) loosening the captive screw and 2) unplugging the electrical connector. Place the pump in a more accessible place to continue.
6. Remove the pump head from the pump as follows (Figure 4-1): with a 5/32" hex wrench, remove the two bolts while holding the pump head against the pump housing (the pump head is under spring tension). Gently pull the pump head straight out from the pump housing, in line with the axis of the piston. Do not tilt the pump head sideways; the piston may break.
7. Inspect the piston. If the piston has scratches on the sapphire, or significant corrosion on the stainless steel piston holder, it should be replaced. Clean any deposits on the sapphire with soapy water, deionized water, and then methanol. If the sapphire cannot be cleaned, the piston should be replaced. Set the cleaned piston in a safe place.
8. Remove the retainer assembly from the pump head. Insert the hooked end of the installation tool into the pump head through the back-up washer and piston seal. Discard the seal. The back-up washer is usually reusable. Do not scratch the walls of the seal cavity with the tool.
9. Inspect the retainer. Clean the retainer if necessary. If there is evidence of wear, or the piston does not fit snugly in the retainer, or the retainer grips the piston too tightly, the retainer should be replaced.
10. This step is only necessary if there are signs of corrosion on the stainless steel piston holder in step 7. Remove the pushrod from the pump housing with round-end tweezers. Inspect for corrosion damage; clean or replace the pushrod if necessary. Coat the pushrod with a light film of SAE 30 oil and re-install with the tweezers.
11. Inspect the pump head, paying special attention to the cavity for the piston seal. Any scratches or irregularities will require replacement of the pump head. The whole pump head may be cleaned with soapy water, and then with deionized water in a sonicator bath.

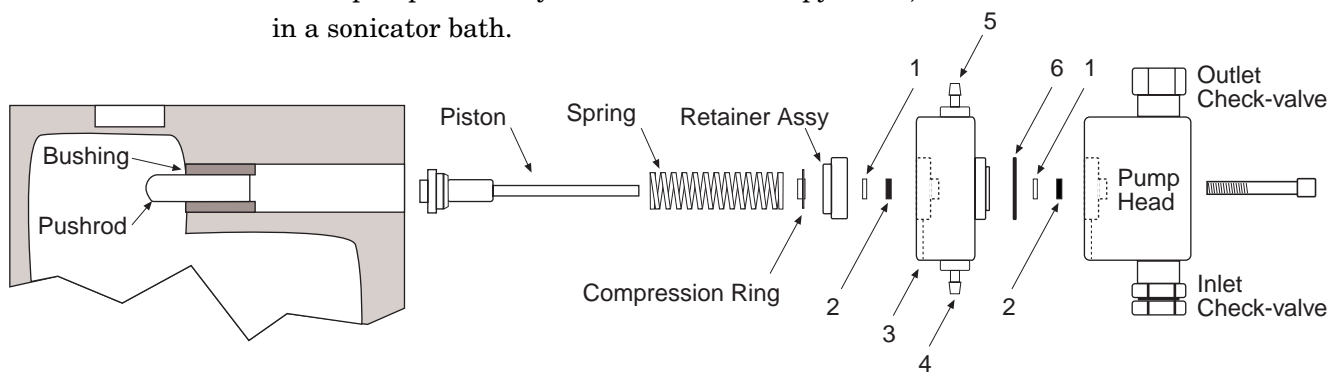

Figure 4-1. Pump assembly with wash system. 1) Back-up Washer; 2) Piston Seal; 3) Wash Cylinder; 4) Inlet Port of the Wash System; 5) Outlet Port of the Wash System; 6) O-ring

12. Insert the installation tool (blunt end) into the retainer assembly and then into the new backup washer and new piston seal. When inserting the new piston seal, the piston seal should lay flat on a hard surface with the spring side down. Insert the tool into the pump head as shown in Figure 4-2. Now the spring side should face the pump head. Keep the tool perpendicular with the face of the pump head. Press gently and evenly on the edge of the retainer assembly with both thumbs. Withdraw the installation tool.

Optional. The piston seal (Figure 4-3) in the wash system also requires periodic replacement. However, it needs not be changed as often as the primary seal. Follow steps 8 and 12 if you desire to replace the seal in the wash system.

13. Reassemble the pump head and wash system as shown in Figure 4-1. Hold the pump assembly firmly in place and reinstall it on the pump, in line with the axis of the piston; do not tilt the pump head sideways.
14. If the post-column pump is a duplex pump, repeat steps 6–13 for reagent 2 side.
15. Replace the pump; tighten the captive screw and reconnect the electrical connection.
16. Reconnect the tubings to the pump head (stabilize the outlet check-valve with a 1/2" wrench when tightening the fitting to prevent the check-valve from moving).
17. Open the intergrated 2-way valve on the reservoir and turn on the gas. Start the PCX5200 and prime the pump.

Figure 4-2. Piston seal replacement with installation tool

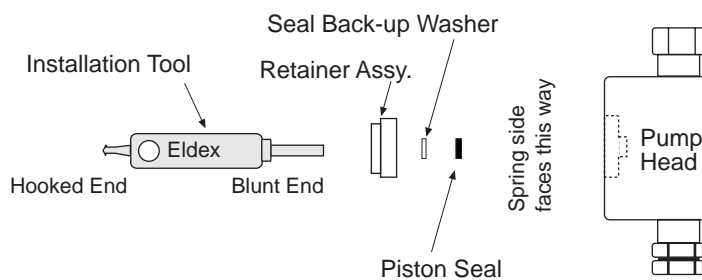
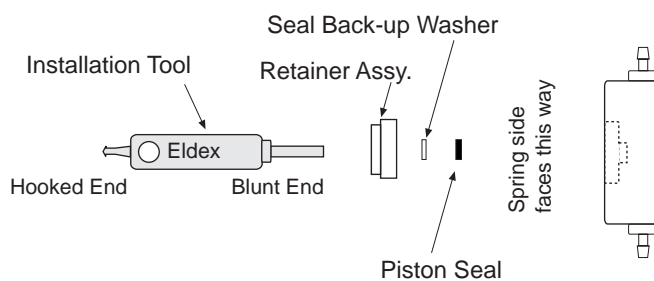

Figure 4-3. Piston seal replacement in the wash system with installation tool



Check-valves Always work with check-valves in a clean area to prevent dust and dirt from entering the pump. The check-valves are the hexagonal-shaped components on the pump head (Figure 4-1). Inlet check-valves can be distinguished from outlet check-valves by the groove on the hexagonal part of the inlet check-valve. Tools needed for check-valve repairs: 1/4" & 1/2" open-end wrench, 5/32" hex wrench. Open-end wrenches are not included.

Cleaning Check-valves Cleaning check-valves is easy and very effective and should be your first consideration in the event of failure.

1. Flush the pump with water, then shut down the post-column system, and let the reactor cool. Turn off the gas and vent the reservoir. Turn off the integrated 2-way valve on the reservoir cap.
2. Remove the flow conditioner panels (center and right) by loosening the captive screws. Remove one flow conditioner at a time. After removing the captive screw, flip the flow conditioner upside down and place it behind the louver (in front of the column oven). You do not need to disconnect any tubings. Repeat the same procedures for the second flow conditioner panel.
3. Disconnect the reagent inlet line from the bottom of the pump head. Wipe up any spilled liquid. Disconnect the outlet tubing from the top of the pump head (stabilize the outlet check-valve with a 1/2" wrench when removing the 1/16" fitting to prevent the check-valve from moving).
4. Remove the pump from the chassis by loosening the captive screw and unplugging the electrical connector. Place the pump in a more accessible place to continue.
5. Remove the pump head from the pump as follows (Figure 4-1): with a 5/32" hex wrench, remove the two bolts while holding the pump head against the pump housing (the pump head is under spring tension). Gently pull the pump head straight out from the pump housing, in line with the axis of the piston. Do not tilt the pump head sideways; the piston may break.
6. Place the pump head in a beaker of soapy water (do not remove the check-valves). Suspend the beaker in a sonicator bath and turn it on maximum power, for 30 minutes
7. Replace the soapy water with deionized water and sonicate for 10 minutes.
8. Reassemble the pump head and wash system as shown in Figure 4-1. Hold the pump assembly firmly in place and reinstall it on the pump, in line with the axis of the piston; do not tilt the pump head sideways.
9. If the post-column pump is a duplex pump, repeat steps 6–8 for reagent 2 side.

10. Replace the pump; 1) tighten the captive screw; 2) reconnect the electrical connection.
11. Reconnect the tubings to the pump head (stabilize the outlet check-valve with a 1/2" wrench when tightening the fitting to prevent the check-valve from moving).
13. Relocate the reservoir and turn on the gas. Start the PCX5200 and prime the pump.

Removing Check-valves

1. Follow steps 1–4 from the Cleaning Check-valves section.
2. To prevent the internal components of the valve from falling out upon removal, keep the pump head in its normal position when removing the inlet check-valve; turn the pump head upside down when removing the outlet check-valve. Remove the check-valves with a 1/2" wrench (counter-clockwise). After removal, keep the valve oriented so the translucent washer faces upwards.

Installing New Check-valves

1. Remove plastic cover.
2. Insert the new inlet check-valve into the pump head and tighten by hand until just finger-tight. Tighten with a 1/2" wrench 1/8 to 1/4 turn more. **Do not overtighten!** The sapphire seats may crack.
3. Turn the pump head upside down; insert the new outlet check-valve into the pump head and tighten by hand until just finger-tight. Tighten with a 1/2" wrench 1/8 to 1/4 turn more. **Do not overtighten!**
4. Reassemble the pump head and wash system as shown in Figure 4-1. Hold the pump assembly firmly in place and reinstall it on the pump, in line with the axis of the piston; do not tilt the pump head sideways.

**Rebuilding
Check-valves**

1. Remove the check-valve cartridge from its housing (Figure 4-4).
2. Insert the smaller dowel pin provided (1/8" od x 1-1/4" long) into the hexagonal end of the valve and press out the internal components of the check-valve assembly using a steady pressure. Do not hammer parts through with the dowel pin or hammer on the dowel pin. Do not allow the valve parts to fall out onto a hard surface.
3. Reassemble the check-valve by placing the valve insert in the valve housing using the larger dowel pin (3/16" od). Make sure that the valve insert is oriented correctly.
4. Press a new Kel-F® valve seal into the valve housing.
5. Slide the check-valve cartridge into the valve housing making certain the cartridge is oriented correctly.
6. Press a second valve seal into the valve housing. This valve seal will extend approximately 0.02–0.03" from the valve housing.

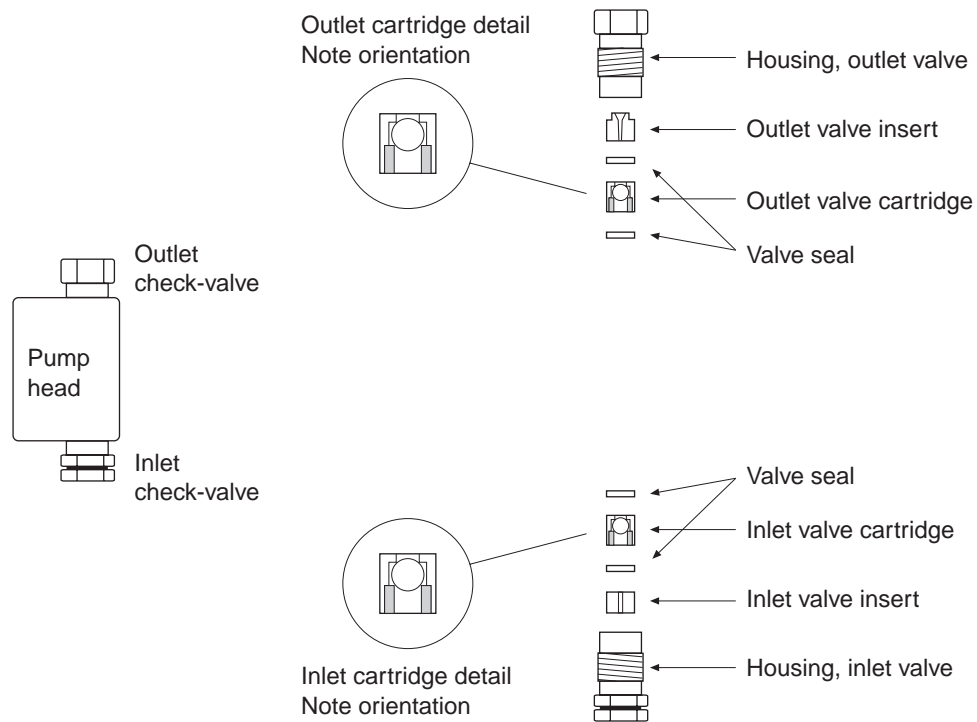

Figure 4-4. Check-valve assemblies

Pre-column Filter The filter is located inside the fitting labelled “From Injector” on the front post-column gauge panel of the PCX5200.

1. Be sure that the PCX5200 is shut down and depressurized (disconnect the “to detector” fitting) before changing the filter.
2. Disconnect the capillary tubing from the fitting. Use a 7/16” wrench to remove the filter element.
3. The correct filter element is 3102-9042, with 0.5 μm porosity. It is superficially similar to the 2 μm reagent filter, so take care not to confuse them.
4. Replace the filter element. Tighten the filter element firmly.
5. Reconnect the capillary tubing.

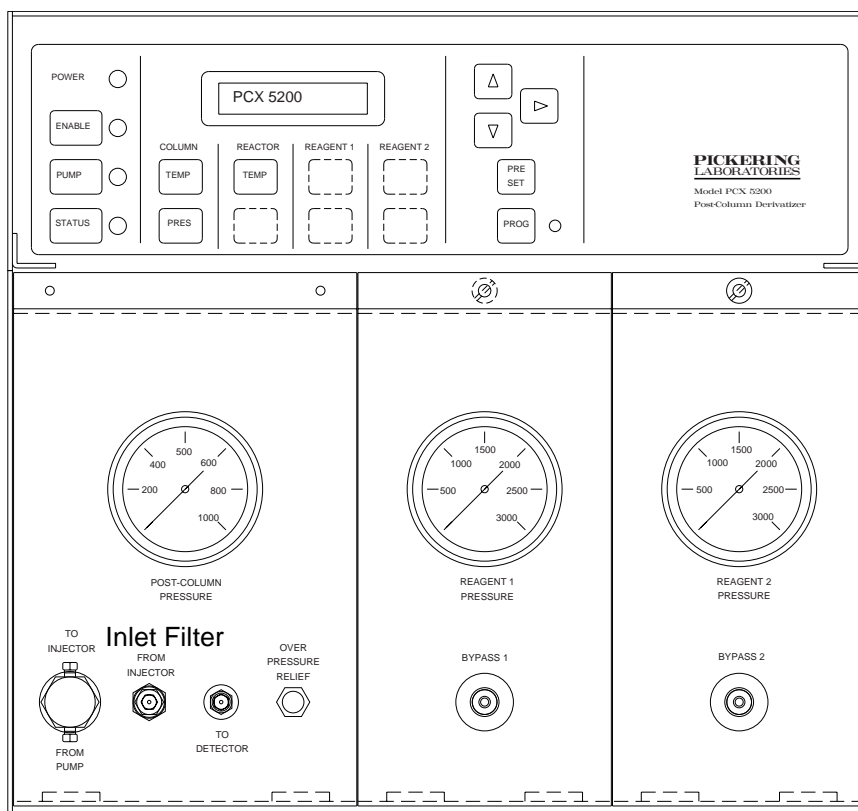

Figure 4-5. 0.5 μm Inlet filter

Reagent Filter These filters are located on the backside of the flow-conditioner panels inside the PCX5200 cabinet. It is easily accessible.

1. Be sure that the PCX5200 is shut down and depressurized before changing a filter.
2. Turn off the gas valve and open the vent valves on the reservoirs. Place the reservoirs at a level below the pump to prevent siphoning of the reagent.
3. Remove the flow conditioner panels (center and right) by loosening the captive screws. Remove one flow conditioner at a time. After removing the captive screw, 1) remove the 1/16" fitting from the pressure gauge tee on the back of the flow conditioner panel; 2) then remove the fingertight fitting on the outlet of the antisiphon valve. Set the detached flow conditioner panel in a more accessible place to continue. Repeat the same procedures for the second flow conditioner panel.
4. Disconnect the tubings from the filter. Use a 7/16 inch wrench and a 9/16 inch wrench to disassemble the filter.
5. Replace the filter element. The correct filter element is 3102-9040, a 2 μm frit. It is superficially similar to the pre-column 0.5 μm filter, so take care not to confuse them. Tighten the fitting firmly.
6. Reconnect the tubings to the filter. The arrow on the side of the filter shows the direction of flow.
7. Reconnect the flow conditioners. The left pump head is Reagent 1. Do not overtighten fittings, finger-tighten the two fittings first and then tighten only the 1/16" stainless steel fitting to the pressure gauge tee with a 1/4" wrench 1/8 to 1/4 turn beyond finger-tight.

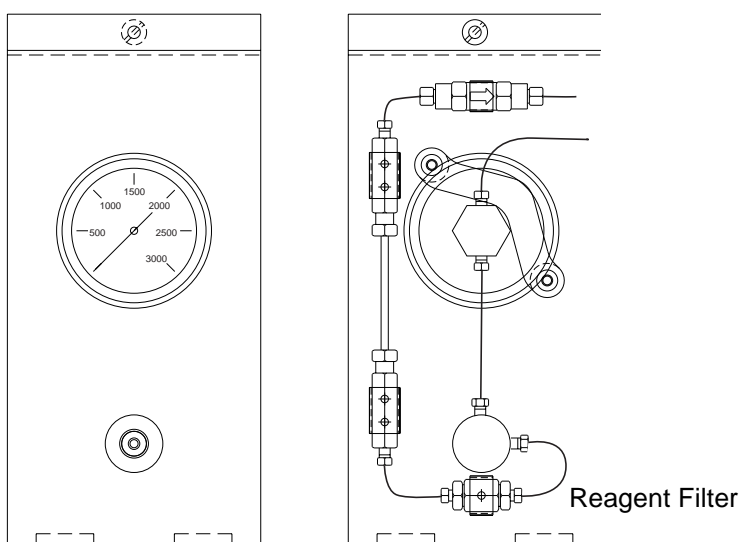

Figure 4-6. Flow-conditioner and 2 μm reagent filter

Ambient Reactor The C₁₈ phase can be hydrolyzed with repeated injections of low pH samples (water (not applicable to samples stabilized with chloroacetic acid or ChlorAC) and can accumulate in the single reagent ambient reactor. Part required: ambient reactor, Cat. No. 1100-2927. PCX5200)

1. Shutdown the post-column system and let the reactor cool for at least 30 min.
2. Remove the post-column panel by loosening the two captive thumb-screws.
3. Disconnect two fingertight fittings
Back side of "To Detector" fitting
Trace the ambient reactor coil to the Reagent 2 Tee and disconnect
4. Install new ambient reactor.
Do not overtighten the fittings.
5. Start the LC pump and inspect for leaks.
6. Reinstall the post-column panel.

Heated Reactor Calcium and magnesium hydroxide precipitates due to hard water and fats and waxes of plant origin are two main causes of clogging in the carbamate analysis systems. For the end-user running a Trione ninhydrin system, the most-likely clogging agent is the precipitation of hydrindantin from expired-Trione ninhydrin solution. Please read the troubleshooting section in the Application Manual for some easy-fixes. Generally, chemical-clogging problems can be solved with chemistry. Changing the heated or ambient reactor is your last resort after attempts to clean the reactor have failed.

1. Shutdown the post-column system and let the reactor cool for at least 30 min.
2. Remove the post-column panel by loosening the two captive thumb-screws.
3. Trace the two tubings from the heated reactor to the post-column panel and disconnect their fingertight fittings.
4. Loosen the two captive thumb-screws that hold the right side of the reactor to the mounting bracket.
5. Disconnect (press and pull) the electrical connector to the heated reactor.
6. Replace the heated reactor.
7. Reconnect the electrical connector.
8. Reconnect the captive thumb-screws on the reactor bracket.
9. Reconnect the two fingertight fittings. Do not overtighten. The inlet and outlet tubings of the heated reactor are interchangeable.
10. Start the LC pump and inspect for leaks
11. Reinstall the post-column panel.

Fuse The line fuse is on the back panel in the power inlet module between the cord connector and the power switch.

1. Remove the cord from the power inlet.
2. Use a small flat screwdriver to pry up the fuse holder then pull the fuse out.
3. Only use the correct type of fuse: for the 120 V instrument, one each, GMA3 type, 3 A, 250 V, 5 x 20 mm, fast acting; for the 240 V instrument, two each, IEC127 type, 1.6 A, 250 V, 5 x 20 mm, fast acting.
4. Reinstall the fuse holder and the power cord.

Troubleshooting Rules of Dolan and Snyder [see references]

Guide • Rule of One: Make one change at a time.

Advice • Rule of Two: Confirm the problem before fixing it.

- Substitution Rule: Swap in a good part for a questionable one.
- Put it Back: If swapping does not fix it, put the original back in.
- Write it Down: Changes or modifications, incidents.
- Crystal Ball: Preventive maintenance saves more time in the long run.
- Buffer Rule: Remove buffers from LC when not in use.

General Procedure for Troubleshooting

- Examine the system front to back. Repair all leaks.
- Verify that all settings, eluants, reagents, valves, etc. are according to specifications.
- Have there been any changes in the system?
- Compare against reference conditions: standard sample, column, parameter log as appropriate.
- Gather information: observations, manuals, books, technical assistance.
- Test your conclusions about the nature of the problem.
- Start working.

When Priming the Reagent Pump is Difficult Sometimes the reagent pump may be very difficult to prime. This can happen after a pump has been shipped, serviced, stored for a long time, or after putting a new bottle of reagent on. Almost always this is due to a trapped bubble inside the pump. Ordinary priming will not always remove the bubble, especially if it is caught inside the piston seal or inside one of the gauges. There are two ways to overcome this.

The first and simplest way is to first prime the pump with a low-surface tension liquid, then change to the normal reagent. Degassed methanol will work well. Simply use the priming syringe to draw about 5 mL of methanol through the pump, then draw 10 mL of reagent through the pump. If there is air in a gauge, the pump may take several minutes to come up to final pressure.

The second and more thorough method is vacuum priming.

1. This can be performed with the pump on or off, it makes little difference.
2. Connect the 20 mL priming syringe to the bypass. Open the Bypass valve. Draw liquid until no bubbles come through. Empty the syringe, and reconnect it to the bypass.
3. Close the liquid shut-off valve on top of the post-column reagent reservoir.
4. Pull a vacuum with the syringe. Hold the vacuum until no more bubbles come out. This causes the trapped bubbles to expand.
5. While still holding a vacuum, open the liquid shut-off valve. This sweeps the expanded bubbles out.
6. Wait until about 5 mL of liquid has collected, then close the bypass valve.
Optional: before closing the bypass valve, use the syringe to apply pressure until the pressure gauge moves. Close the valve while holding pressure on the system.
7. If the pump is not on, turn it on.
8. The pressure should come up within a few seconds. If it does not begin pulsing within 30 sec., repeat steps 3–8. If you can not prime the pump after 2 or 3 applications of vacuum, then there is some other problem. Check for leaking piston seals, dirty check valves, loose fittings, or other defects.

Interpretation of Pressures The most useful diagnostic tool is a pressure log. Note that it is important to record all four pressures under initial conditions. Each permutation indicates a specific problem.



Note: These pressures are typical and may vary slightly depending on the system and the application. It is very important to know the initial pressures specific to your system.

Two-reagent PCX5200	Condition	Column	Post-Column	Reagent 1	Reagent 2
	Normal	1200	250	1500	1500
	Pre-column filter blocked	↑	—	—	—
	Heated reactor obstructed	↑	↑	↑	—
	Ambient reactor obstructed	↑	↑	↑	↑
	Reagent 1 not pumping	—	↓	↓	—
	Reagent 2 not pumping	—	↓	—	↓
	Restrictor 1 blocked	—	—	↑	—
	Restrictor 2 blocked	—	—	—	↑

One-reagent PCX5200	Condition	Column	Post-Column	Reagent
	Normal	1200	250	1500
	Pre-column filter blocked	↑	—	—
	Reactor obstructed	↑	↑	↑
	Reagent not pumping	—	↓	↓
	Restrictor blocked	—	—	↑

There is also detailed section on troubleshooting in the Application Manual.

Cleaning the Post-column System Always wear safety glasses or goggles, laboratory coat, gloves, and other appropriate safety-clothing. Please read and understand the instructions in the MSDS's shipped with the chemicals. If the MSDS's are missing, please contact Pickering Laboratories and we can instantly fax you a copy.

Fittings Thoroughly clean any leaks from fittings with water and dry with paper towels, especially if the solution is a buffer or hydroxide. Standing salt and hydroxide solution are corrosive.

External Soak up spills with rags, paper towels, or sponge. Clean spill-area with a wet towel and thoroughly dry. Do not spray water directly into the instrument.

Internal Vacuum clean inside the post-column system once a year.

1. Open the column oven door.
2. The reagent flow conditioners can be removed by removing two captive screws. Set the flow conditioners upside down in the front of the column oven. You do not need to disconnect any tubings.
3. The post-column panel can be removed by removing two captive screws. Set this panel sideways in front of the PCX5200.
4. Vacuum clean the inside.
5. Reinstall the panels.

Internal Spill Follow the directions listed above to get inside the system. Soak up spills and leaks with rags, paper towels, or sponge. Clean spill-area with a wet towel or water from a squeeze bottle and thoroughly dry. Do not spray water directly into the electrical part of the post-column pump.

PCX 5200 Parameter Log

Reagent Pump Calibration

Pump 1

Micrometer	Flow Rate	Medium

Pump 2

Micrometer	Flow Rate	Medium

Normal Pressures and Flows at Initial Conditions

	Flow Rate	Pressure
Analytical Pump		
Reagent Pump 1		
Reagent Pump 2		
Post-Column		

	Temperature
Analytical Column	
Heated Reactor	
Room	

Tested by: Date:

Analytical Conditions

LC Program:

Initial Composition: Initial Flow Rate:

Gradient Program:

Column:

Type: ID: Temperature:

Injector/Autosampler:

Sample: Volume: Solvent:

Manual/Auto: Other Parameters:

Detector:

Excitation: Band: Emission: Band:

Range: PMT: Lamp: Resp. time:

Integrator or Data Station:

Range or Scale: Units: Attenuation:

Chart Speed: Peak Threshold: Width:

Run Time:

Operator: Date: Reference:

Post-column Band-spreading Test

Test Conditions

LC

Eluent: 60 / 40; methanol / water

Flow rate: 1.0 mL/min

Sample: Pickering carbamate test mixture, Cat. No. 1700-0063, 10 µL

Column: Type ID

Temperature: 42°C

Detector: Excitation Emission Lamp PMT gain Range/Attn

Integrator: Range / Attn Units Multiplier Chart speed

Method for calculating peak width:

Part 1: Column connected directly to the detector
 Post-column pumps off, reactor temperature ≤ 55°C

<u>Run #</u>	<u>Retention time</u>	<u>Peak width</u>	
_____	_____	_____	=W _d
Average			

Part 2: Post-column reactors connected to column and detector
 Post-column pumps off, normal reactor temperature

<u>Run #</u>	<u>Retention time</u>	<u>Peak width</u>	
_____	_____	_____	=W _{pc}
Average			

Ratio: W_d / W_{pc} =

Operator: **Date:**

Post-column Delay

The post-column delay volume is about 600 μL . The delay time can be calculated as:

$$t = [0.5/(f_e + f_{R1})] + [0.1/(f_e + f_{R1} + f_{R2})]$$

where f_e is eluant flow rate, f_{R1} is first reagent flow rate, and f_{R2} is second reagent flow rate; 0.5 is the volume of the first reactor and 0.1 is the volume of the second.

Appendix B

Spare Parts

Part Number	Description
3102-9042	Replacement frit, 0.5 µm (for pre-column filter)
3102-9040	Replacement frit, 2 µm (for reagent filters)
1100-2927	OPA Reactor, 0.011" ID TFE tubing
1100-0281	0.5mL Coil Assembly only, no heater
1100-2660	Heated Reactor, 0.5mL, 120 V (other volumes on request)
1100-2661	Heated Reactor, 0.5mL, 240 V
1100-0200	Restrictor, for OPA, NaOCl, & NaOH reagent, with nuts & ferrules
1100-0141	Restrictor, Trione Ninhydrin, with nuts & ferrules
3106-1330	Seal (1) for reagent pump
3106-1310	Seal Kit for reagent pump, includes 2 seals and seal installation tool
3106-1314	Inlet Check Valve for reagent pump
3106-1316	Outlet Check Valve for reagent pump
3106-1332	Piston, sapphire, for reagent pump with piston-washing system
3106-1322	Piston Guide / Retainer
3106-1324	Liquid End Assembly
3107-0137	Reagent bottle, coated, 1 liter borosilicate, with cap, for storage
3107-0300	Reagent bottle assembly, cap with integrated 2-way valve
2103-0463	Tubing, Saran, 1/8" OD x 0.063" ID, per 3 ft (90 cm)
3104-0081	Seal Kit for bypass valve
3101-0060	Nut, Fingertight for 1/16" plastic tubing
3102-1202	Nut, male, Upchurch type, 10-32, 1/16"
3102-2102	Ferrule, Upchurch type, 1/16"
3102-1402	Nut, male, Valco type, 10-32, 1/16"
3102-2402	Ferrule, Valco type, 1/16"
3103-1030	Tubing, stainless steel, 1/16" OD x 0.010" ID x 30 cm
2101-0212	Tubing, TFE, 1/16" OD x 0.011" ID, per 3 ft (90 cm)
2101-0225	Tubing, TFE, 1/16" OD x 0.025" ID, per 3 ft (90 cm) (waste line)
3101-0007	Nut, 1/4-28 x 1/16"
3101-0008	Ferrule, for 1/4-28 x 1/16"
3101-0005	Nut, 1/4-28 x 1/8"
3101-0006	Ferrule, for 1/4-28 x 1/8"
3102-1518	Nut, Lite-Touch, for 10-32, 1/16"
3102-2507	Ferrule, Lite-Touch, for 10-32, 1/16"
3543-0045	Fuse for PCX5200, 120 V
3543-0044	Fuse for PCX5200, 240 V

References

Carbamates

- “Measurement of N-methyl carbamoyloximes and N-methyl carbamates in drinking water by direct aqueous injection LC with post-column derivatization,” EPA Method 531 by D.L. Foerst, EPA/600/4-851054 (1986); Method 5, revised by T. Engels, National Pesticide Survey, Battelle Columbus Lab (1987); Method 531.1, revised by R.L. Graves, EPA, Environmental Monitoring and Support Laboratory, Cincinnati (1989).
- M. W. Dong, F.L. Vandemark, W.M. Reuter, and M.V. Pickering, “Carbamate pesticides analysis by liquid chromatography,” *Amer. Environ. Lab.*, **2**(3) (1991) 14–27.
- K.M. Hill, R.H. Hollowell, and L. D. Dal Cortivo, “Determination of N-methylcarbamate pesticides in well water by liquid chromatography with post-column fluorescence derivatization,” *Anal. Chem.*, **56** (1984) 2465–2475.
- H. Frister, H. Meisel, and E. Schlimme, “OPA Method Modified by Use of N,N-Dimethyl-2-mercaptoethylammonium Chloride,” *Fresenius Z. Anal. Chem.*, **330** (1988) 631–633.

Glyphosate

- J.E. Cowell, “Analytical Residue Method for N-Phosphono-methylglycine and Aminomethylphosphonic acid in Environmental Water,” *Monsanto Method Number 86-63-1*, 1987
- Environmental Protection Agency Draft Method 597: “Analysis of Glyphosate in Drinking Water by Direct Aqueous Injection LC with Post-Column Derivatization.”

Instrumentation

- M.V. Pickering, “Assembling an HPLC post-column system: practical considerations,” *LC•GC*, **6**, 11 (1988) 994–997.†
- M.V. Pickering, “Modifying HPLC equipment to tolerate corrosive solutions,” *LC•GC*, **6**, 9 (1988) 800–809.†
- J.W. Dolan and L.R. Snyder, “Troubleshooting LC Systems,” Humana Press, Clifton, NJ (1989).

† Reprints available from Pickering Laboratories

Amino Acid Analysis

- D.H. Spackman, W.H. Stein and S. Moore, *Anal. Chem.*, **30** (1958) 1190.
- M.V. Pickering, *LC•GC*, **7** (1988) 484.†
- J.A. Grunau and J.M. Swiader, *J. Chromatogr.*, **594** (1992) 165.†
- A.A. Boulton, G.B. Baker, and J.D. Wood (Eds.), "Neuromethods 3, Amino Acids," Humana Press, Clifton, NJ (1985), Chapter 1.

Limited Warranty

Instruments

Pickering Laboratories, Inc., (Pickering) Instruments in standard configuration (see Instrument List below) are warranted to be free of defects in material and workmanship under normal installation, use, and maintenance, for a period of one year from the date of delivery to the original Customer. Pickering will replace or repair, without cost, any defective items. Expendable items such as check valves, pistons, piston seals, and filters are excluded from this warranty. In addition, physical damage, poor-quality reagent- and sample-induced damage, and instrument damage due to Customer's misuse are not covered by this warranty.

Instrument List

CRX400

CHX700

PCX5200 Cat.Nos. 1152-1xxx and 1152-2xxx

Analytical Columns

Pickering's Analytical Columns are warranted to be free of defects in materials and workmanship under normal installation, use, and maintenance, for the warranted time beginning from the date of delivery to the original Customer. Pickering will replace the Analytical Column under warranty if found defective in material or workmanship. However, the warranty is void if the Analytical Column was damaged due to Customer's misuse. Ion Exchange columns for Amino Acid Analysis, Glyphosate, and ALKION columns are warranted for 90 days. Silica-based reversed-phase columns are warranted for 30 days.

How to Obtain Warranty Service

If there is a problem with your Instrument or Analytical Column within the Warranty period, immediately notify Pickering at **(800) 654-3330**; if calling from outside U.S.A., use **(650) 694-6700**. If the Instrument or Analytical Column was not purchased directly from Pickering, please contact the vendor where it was purchased. Any Instrument, part of the Instrument, or Analytical Column returned to Pickering for examination or repair shall have Pickering's prior approval (call for a Returned Goods Authorization number) and be sent prepaid by the Customer. Return transportation will be at Pickering's expense if the Instrument, part of the Instrument, or Analytical Column is found to be defective and under warranty.

Pickering Laboratories, Inc.
1280 Space Park Way
Mountain View, CA 94043
U.S.A.

-
- A**
- Alkaline 3-1
 - Ambient reactor 4-11
 - Anti-siphon valve 1-2
 - Application kits 3-1
- B**
- Back-flow prevention 4-2
 - Back-pressure regulator 1-3, 3-1, 3-6
 - Boiling 3-1
 - Bourdon tube 1-2
- C**
- Calibration (column oven, reactor) 2-19
 - Caution 3-4, 3-6
 - Check-valves 4-6
 - Cleaning check-valves 4-6
 - Cleaning the post-column system 4-15
 - Column installation 3-7
 - Column oven 2-6
 - Column protection 1-2
 - Communicating with a computer 2-21
 - Corrosive eluants 3-5
- D**
- Depressurized 4-2
 - Design of an HPLC 1-4
 - Designing a post-column system 1-5
 - Detector 3-1
 - Detector connections 3-6
 - Downloading firmware 2-21
- E**
- Electrical precaution 4-2
 - Electrical requirement 3-2
 - ENABLE key 2-10
- F**
- Filter, pre-column 4-9
 - Filter, reagent 4-10
 - Fittings 3-3
 - Flow diagrams 2-18
 - Flow-conditioner 1-6, 2-3
 - Flow-conditioner panel 2-1
 - Front panels 2-1
 - Fuse 4-12
 - Fuse 2-4
- G**
- Gas pressure system 2-9
 - Gas regulator 2-9
 - Gauge 1-2
 - Guard 3-7
- H**
- Heated reactor 4-11
 - HPLC system requirements 3-1
- I**
- Inert gas 3-2, 3-3
 - Injector connections 3-6
 - Installing new check-valves 4-7
 - Interpretation of pressures 4-14
- K**
- Keypad 2-10
 - Keypad examples 2-13
- L**
- Layout of HPLC & PCX5200 3-2
 - LED (light emitting diode) 2-11, 2-12
 - Liquid connections 2-1
 - LCD (liquid crystal display) 2-10

M

Main power 2-4
Maximum temperature 2-12
Miscellaneous supplies 3-2
MSDS 3-1

O

Over-pressure relief 2-1

P

PEEK fittings 3-3
Piston-wash system 2-3, 3-8
Post-column derivatization 1-1
Post-column panel 2-1
Pre-column filter 4-9
Preset programs 2-13
Pressure gauge 1-2
Pressure-interlock 3-5
Pressure-interlock connections 3-4
Pressurized reservoir 1-2
Priming the reagent pump 3-9
PRESET key 2-18
PROG key 2-18
PUMP key 2-10
Pump seal replacement 4-3

R

Radio frequency 2-21
Reactor precautions 4-2
Reagent filter 4-10
Reagent pump 3-8
Reagent reservoir 2-8, 3-3
Rebuilding check-valves 4-8
Removing check-valves 4-7
Reservoir 3-3
Reversed-ferrule 3-3
Reagent pump 4-3
Rotor seal 3-1
Routine maintenance 4-3
RS232 2-4, 2-21

S

Saran tubing 3-3
Saving a Preset program 2-15
Seal replacement, reagent pump 4-3
Shutdown 3-10
Slowdown program 3-10
Space requirements 3-2
Specifications 2-20
Spill, cleaning 4-15
STATUS key 2-10
System testing 3-9

T

Tefzel rotor seal 3-1
TEMP key 2-10
Troubleshooting guide 4-12

V

Vacuum priming 4-13
Vespel rotor seal 3-1

W

Warranty registration 3-1
Wetted materials 2-20
When priming the reagent
pump is difficult 4-13